

Wilfrid Laurier University

Scholars Commons @ Laurier

Theses and Dissertations (Comprehensive)

2014

Microbial community characterization and pathogen profiling of land-based aquaculture systems using culture-based and molecular-based fingerprinting techniques

Nicole S. Kteily

Wilfrid Laurier University, nicole_kteily@hotmail.com

Follow this and additional works at: <https://scholars.wlu.ca/etd>



Part of the Integrative Biology Commons

Recommended Citation

Kteily, Nicole S., "Microbial community characterization and pathogen profiling of land-based aquaculture systems using culture-based and molecular-based fingerprinting techniques" (2014). *Theses and Dissertations (Comprehensive)*. 1691.

<https://scholars.wlu.ca/etd/1691>

This Thesis is brought to you for free and open access by Scholars Commons @ Laurier. It has been accepted for inclusion in Theses and Dissertations (Comprehensive) by an authorized administrator of Scholars Commons @ Laurier. For more information, please contact scholarscommons@wlu.ca.

Microbial community characterization and pathogen profiling of land-based aquaculture systems using culture-based and molecular-based fingerprinting techniques

By

Nicole S. Kteily

Honours B.Sc. Biology, Wilfrid Laurier University, 2012

THESIS

Submitted to the Department of Biology

Faculty of Science

in partial fulfillment of the requirements for the

Master of Science in Integrative Biology

Wilfrid Laurier University

2014

Nicole S. Kteily 2014©

Abstract

The growing worldwide demand for fish production has prompted research towards intensive aquaculture. Innovative system designs, such as recirculating and flow-through aquaculture systems, have been developed to improve the efficiency and sustainability of intensive aquaculture practices. These LBAS systems exhibit a wide range of spatial and temporal heterogeneity. Although such heterogeneity suggests the potential for culture water to support a diverse and spatially complex assortment of microorganisms, there is a lack of information regarding the overall diversity and composition of microbial communities (including pathogens) in the different compartments of these systems. To better understand the diversity and functionality of microbial communities within different aquaculture systems, a field-based approach was taken to gain perspective on the spatial and temporal variation of microbial communities in aquaculture systems of varying design, including: two pilot-scale recirculating systems, each utilizing a different wastewater treatment technology; and two field-scale flow-through aquaculture systems. Of particular interest was gaining a better understanding of microbial community balance on the retention of organisms with pathogenic potential, including the fecal indicator bacteria *E. coli* and *Enterococcus* spp., as well as the fish pathogens *Yersinia* spp. and *Aeromonas* spp. An integrative approach to phenotypic (culture-based) and genotypic (molecular-based) analysis was taken to profile test microorganisms at multiple levels. Specifically, a media-based plate count approach was used to enumerate the heterotrophic and pathogenic bacterial levels, as well as removals, from the aquaculture environment. Additionally, ABR analysis was conducted for resistance profiling of select pathogens isolated from a local FTS against a panel of 12 antibiotics. The functional and structural fingerprints of the communities were investigated by community-level physiological profiling (CLPP) and denaturing gradient gel electrophoresis (DGGE), respectively. Cultivation results indicated the presence of *Yersinia* spp. and *Aeromonas* spp. within all system designs, with abundances of *Yersinia* spp. typically detected more frequently within the respective systems compared to *Aeromonas* spp. Pathogen levels in recirculating systems were observed to be sensitive to various wastewater treatment approaches, including NMB and UF technologies. Field-scale FTS results indicated spatial variation of microbial communities and pathogens, with a greater frequency of heterotrophic and pathogenic bacteria observed within effluent waters compared to influent. Functional and structural profiling of communities within recirculating and flow-through systems revealed distinct profiles for the different systems, each harbouring genetically and metabolically diverse communities, including communities demonstrating high metabolic versatility but low genetic diversity. Comparatively, the recirculating systems appeared to support more functionally and structurally stable communities than the flow-through systems, based on CLPP and DGGE results. Collectively, these findings suggest that microbial communities within different exhibit distinct responses to varying environmental parameters. Moreover, the use of NMB and UF wastewater treatment approaches may allow for the enhanced ability to manage pathogen loads within these systems. This information presents new knowledge on bacterial community composition and functionality in various parts of recirculating and flow-through systems, which constitute essential tools for overall aquaculture system management.

Acknowledgements

My deepest gratitude goes to my family. Mom and Dad – I will never find the words to accurately express my appreciation for everything you have done, and everything you have sacrificed. Thank you for fostering my love of science from the very beginning. I will forever cherish the memories of every science project and library trip. Your hard-work, academic curiosity, and love of life have served as a continuous example of how to both enjoy, and excel at any endeavor - both personal and academic. My accomplishments and strength of conviction are a direct result of the foundation you have built, and your unwavering belief in my abilities. Alexandra – thank you for unknowingly serving as my role model. You have exposed me to a spectrum of colours I never knew existed. In doing so, you have inadvertently made me a better scientist. Science and art truly do go hand-in-hand.

My utmost thanks and sincere gratitude go to my supervisor, Dr. Robin Slawson. Your words of wisdom and advice have always been received with the highest degree of respect. You have been an incredible role model, both personally and professionally. Your expertise has guided me through many projects, both big and small, and I am truly grateful for this opportunity and the knowledge I have gained.

I extend my thanks and gratitude to my advisory committee, Dr. Joel Weadge and Dr. Brent Wootton. Your input, support, and stimulating discussions have been motivating influences during this academic journey. I would also like to acknowledge the Ontario Ministry of Agriculture, Food and Rural Affairs for providing the financial support to make this study possible.

To all of my friends - thank you for pretending to understand what it is that I do, and for keeping a straight face when I excitedly describe my work. Thank you for continually reminding me that there is a world outside of my lab, and for your words of support and encouragement along the way. I will forever be grateful for the moments of laughter that broke through when it was needed most. To the remainder of the Laurier Science community, thank you for creating a learning environment that was both enjoyable and supportive.

Dylan – my lighthouse. Thank you for illuminating the darkness and keeping me from crashing into the rocks.

To my grandparents – Teta Helen, Jiddo Elian, and Teta Souad – No published work of literature will ever impart the wisdom you have bestowed. Please know how important your presence has been in my life, and how your influence has shaped my character.

To the dearly departed – Jiddo Essa, Teta Soulange, and Uncle Ted – Your infinite love and support will forever transcend space and time. Thank you for reminding me to cherish every moment, and appreciate the power of things too small to be seen with the naked eye.

If I have seen further, it is by standing on the shoulders of giants

-Sir Isaac Newton

Table of Contents

Abstract	ii
Acknowledgements	iii
List of Figures	viii
List of Tables	xii
List of Abbreviations	xiii
Chapter 1: Introduction	1
1.1 Background	1
1.1.1 Global Aquaculture Practices	1
1.1.2 Land-based Aquaculture Systems.....	3
1.1.3 The Role of Microbial Communities within Aquaculture Systems	5
1.1.4 Microbial Community Characterization within Aquaculture Systems.....	8
1.1.5 Pathogenic Microorganisms Associated with Rearing Practices.....	10
1.1.6 Wastewater Treatment Approaches.....	14
1.2 Research Need and Thesis Objectives	17
Chapter 2: Materials and Methods.....	21
2.1 Overview of Experimental Approach	21
2.2 Site Descriptions and Sampling Protocols	22
2.2.1 Sampling Regimens	25
2.3 Characterization of the Microbial Community and Environmental Pathogens	28
2.3.1 Culture-Based Methods	28
2.3.1.1 Heterotrophic Plate Counts.....	28

2.3.1.2 Recovery, isolation and enumeration of select environmental pathogens.....	29
2.3.1.3 Isolation and enumeration of water quality indicator organisms	31
2.3.1.4 Antibiotic Resistance Profiling.....	32
2.3.1.5 Community-Level Physiological Profiling.....	34
2.3.2 Molecular-based Methods.....	41
2.3.2.1 Denaturing Gradient Gel Electrophoresis	45
Chapter 3: Results of Flow-Through Systems	53
3.1 <i>E. coli</i> , <i>Enterococcus</i> spp. and Heterotrophic Plate Count Enumerations	53
3.2 Enumeration of Select Fish Pathogens in Flow-through Aquaculture Systems	59
3.2.1 Qualitative PCR to Confirm and Characterize <i>Yersinia</i> spp. and <i>Aeromonas</i> spp.	65
3.2.2 Frequency of Antibiotic Resistance among Waterborne <i>Yersinia</i> spp., and <i>Aeromonas</i> spp. isolated from a Local Flow-Through System (FTS-B).....	67
3.3 Community-Level Physiological Profiling of Communities	72
3.4 Structural Fingerprinting of Microbial Communities through DGGE.....	77
Chapter 4: Results for Recirculating Systems	84
4.1 <i>E. coli</i> , <i>Enterococcus</i> spp. and Heterotrophic Plate Count Enumerations	84
4.2. Enumeration of Select Fish Pathogens in a Pilot-Scale Recirculating Aquaculture Systems Utilizing Water Treatment Technologies	89
4.2.1 Qualitative PCR to Confirm and Characterize <i>Yersinia</i> spp. and <i>Aeromonas</i> spp.	97
4.3 Community-Level Physiological Profiling of Communities from Pilot-scale Recirculating Aquaculture Systems	99
4.4 Structural Fingerprinting of Microbial Communities in a RAS using PCR-DGGE	105
Chapter 5: Discussion.....	114

5.1 Comparison of Group Specific Media-based Enumeration and Characterization in Aquaculture Systems of Varying Scale and Design	114
5.1.1 Enumeration and Comparison of the Heterotrophic Communities	114
5.1.2 Consideration of the Presence of Classical Fecal Indicator Bacteria <i>E. coli</i> and <i>Enterococcus</i> spp., and fish Pathogens <i>Yersinia</i> spp. and <i>Aeromonas</i> spp.	120
5.1.2.1 Genotypic Confirmation of <i>Yersinia</i> spp. and <i>Aeromonas</i> spp.....	129
5.1.2.2 Frequency and Distribution of Antibiotic Resistance among Waterborne <i>Yersinia</i> spp. and <i>Aeromonas</i> spp. isolates from a Local Flow-Through System	135
5.2 Microbial Community Integrity in Aquaculture Systems as Measured through Functional and Structural Profiling Techniques.....	141
Chapter 6: Overall Conclusions	155
6.1 Research Overview	155
6.2 Summary of Major Findings	155
6.3 Future Research.....	157
6.4 Concluding Remarks and Integrative Nature of Thesis	159
References	161
A- Supplementary Tables and Figures	173

List of Figures

- Figure 1.1.** Continuum of aquaculture production methods (adapted from Stickney, 1994). 3
- Figure 2.2.** Reduction of tetrazolium violet dye incorporated into Biolog EcoPlates™ 35
- Figure 2.3.** Representation of a Biolog EcoPlate™ inoculated with an environmental water sample following 96 hours of incubation. Purple colouration within a well indicates respiratory activity and utilization of respective carbon source. Blank wells are included in triplicate within the top row, in wells 1, 5 and 9. 36
- Figure 3.1.** Representation of total cultureable heterotrophic plate counts (HPC) as colony-forming units (CFUs) per mL over the sampling dates from February 2013 to April 2014 within the northern flow-through system (FTS). 55
- Figure 3.2.** Mean values of (A) *E. coli* and (B) *Enterococcus* spp. as colony-forming units (CFUs) per 100 mL over two sampling dates in June (2013) and May (2014) within the local flow-through aquaculture system (FTS-B). Error bars represent standard deviation around mean values. 57
- Figure 3.3.** Representation of total cultureable heterotrophic plate counts (HPC) as colony-forming units (CFUs) per mL over the sampling dates in June (2013) and May (2014) within the local flow-through system (FTS-B). Error bars represent standard deviation around mean values. 58
- Figure 3.4.** Enumeration results of total cultureable *Yersinia* spp. (A) and *Aeromonas* spp. (B) as colony-forming units (CFUs) per 100 mL from respective sampling locations in a northern flow-through aquaculture system (FTS-A) monitored across four seasons. 62
- Figure 3.5.** Enumeration results of total cultureable *Yersinia* spp. (A) and *Aeromonas* spp. (B) as colony-forming units (CFUs) per 100 mL from respective sampling locations in a local flow-through aquaculture system monitored across two summer sampling dates in June 2013 and May 2014 (FTS-B). 64
- Figure 3.6.** Percentage of resistance demonstrated in FTS-B *Yersinia* spp. (A) and *Aeromonas* spp. (B) isolates to a range of antibiotics over two sampling events on June 18th, 2013 and May 13th, 2014. 71
- Figure 3.7.** Community-level physiological profiles (CLPP) of microbial communities from the FTS-A based on (A) average well colour development, (B) metabolic diversity and (C) metabolic richness following a 96 hr incubation period. 74
- Figure 3.8.** Community-level physiological profiles (CLPP) of microbial communities from the FTS-B based on (A) average well colour development, (B) metabolic diversity and (C) metabolic richness following a 96 hr incubation period. 76
- Figure 3.9.** DGGE-based community analysis of FTS-A samples obtained according to sampling location within the system and date, including (A) species diversity calculated

using the Shannon Index (H') and (B) species richness as interpreted by number of bands within each sample. 78

Figure 3.10. DGGE-based averaged banding patterns generated for sampling locations of the FTS-A and seasonal sampling dates including (A) well water, (B) raceway water, (C) treatment pond and (D) polishing pond. 80

Figure 3.11. DGGE-based community analysis of FTS-B samples obtained according to sampling location within the system and date, including (A) species diversity calculated using the Shannon Index (H') and (B) species richness as interpreted by number of bands within each sample..... 82

Figure 3.12. DGGE-based averaged banding patterns generated for sampling locations of the FTS-B during two summer sampling events in June 2013 (top) and May 2014 (bottom). 83

Figure 4.1. Representation of total cultureable heterotrophic plate counts (HPCs) as colony-forming units (CFUs) per mL over the sampling dates within the nano-membrane bioreactor (NMB) pilot-scale system. The sampling week listed corresponds to various sampling dates in the 16-week monitoring period between February and May 2013. 86

Figure 4.2. Representation of total cultureable heterotrophic plate counts (HPC) as colony-forming units (CFUs) per mL over the sampling dates within a recirculating aquaculture system employing ultra-filtration technology. The sampling weeks listed corresponds to various dates between February and May 2013. 4.2. Enumeration of Select Fish Pathogens in a Pilot-Scale Recirculating Aquaculture Systems Utilizing Water Treatment Technologies 88

Figure 4.3. Enumeration results of total cultureable *Yersinia* spp. (A) and *Aeromonas* spp. (B) as colony-forming units (CFUs) per 100 mL from respective sampling locations in a pilot-scale recirculating aquaculture system employing a nano-membrane bioreactor (RAS-A). The sample weeks listed corresponds to various dates within the 16-week monitoring period that occurred between February and May 2014. 93

Figure 4.4. Enumeration results of total cultureable *Yersinia* spp. (A) and *Aeromonas* spp. (B) as colony-forming units (CFUs) per 100 mL from respective sampling locations in a pilot-scale recirculating aquaculture system employing an ultra-filtration technology (RAS-B). The sample weeks listed corresponds to various dates within the 16-week monitoring period that occurred between February and May 2014. 96

Figure 4.5 Community-level physiological profiles (CLPP) of microbial communities from the pilot-scale RAS utilizing NMB technology based on (A) average well colour development, (B) metabolic diversity and (C) metabolic richness following a 96 hr incubation period.101

Figure 4.6 Community-level physiological profiles (CLPP) of microbial communities from the pilot-scale RAS utilizing UF technology based on (A) average well colour development, (B) metabolic diversity and (C) metabolic richness following a 96 hr incubation period.104

Figure 4.7. DGGE-based community analysis of the nano-membrane bioreactor treated system (RAS-A) samples collected over the duration of the 16-week monitoring period from February to May 2014, including (A) species diversity calculated using the Shannon Index (H') and (B) species richness as interpreted by number of bands representing operational taxonomic units (OTUs) within the respective sample.....	107
Figure 4.8. DGGE-based averaged banding plot for all samples obtained throughout the 16-week experimental monitoring period from the pilot-scale recirculating aquaculture system (RAS-A) employing a nano-membrane bioreactor. The sampling weeks listed corresponds to various dates between February and May 2013.	109
Figure 4.9. DGGE-based community analysis of the ultra-filtration treated system (RAS-B) samples collected over the duration of the 16-week monitoring period from February to May 2014, including (A) species diversity calculated using the Shannon Index (H') and (B) species richness as interpreted by number of bands representing operational taxonomic units (OTUs) within the respective sample.....	111
Figure 4.10. DGGE-based averaged banding patterns generated for sampling locations of the RAS-A and sampling dates for all sampling events in February, March, April and May (2014).....	113
Figure A1. Schematic representation of the nano-membrane bioreactor treatment technology (NMB) provided by BioGill™. Wastewater is re-circulated through the set of gills via a pump, returning to the tank under the effects of gravity. Each gill consists of a pair of planar membranes oriented vertically with the liquid trickling down between them. Air surrounding the gills provides the oxygen to feed the growing biomass (biofilm) that grows on the membranes from the outside, while soluble nutrients are located in the inner lumen of the gills and feed the microbial population.	175
Figure A2. Schematic of the ultra-filtration technology set up within the pilot-scale recirculating system. (image provided by Skyhydrant™).....	176
Figure A3. Representation of the Biolog© EcoPlate™ containing 31 carbon sources in triplicate. (image adapted from www.biolog.com).....	177
Figure A4. Sample image of an 8% DGGE gel with a urea/formamide gradient of 40-65% used to separate DNA fragments from the pilot-scale UF treated system (weeks 1, 3, 5, 7) amplified with primer pair 357f-GC-518r. Ladder is in lane 1. All other lanes are loaded with sample.	178
Figure A5. Sample image of an 8% DGGE gel with a urea/formamide gradient of 40-65% used to separate DNA fragments from the Northern flow-through system (FTS-A) amplified with primer pair 357f-GC-518r. Ladder is in lane 1. All other lanes are loaded with sample.	179
Figure A6. Schematic of recirculating hatchery from which influent water supplying pilot-scale systems A and B (RAS-A and RAS-B) are derived.	180

Figure A7. Schematic of local flow-through aquaculture system depicting water flow and hatchery design. Sample locations are denoted by asterisks..... 174

List of Tables

Table 2.1. PCR primers, products, and reference strains for <i>Y. enterocolitica</i> , <i>Y. ruckeri</i> and spp. used for identification and confirmation	44
Table 3.1 Summary of the total number of <i>Yersinia</i> spp., <i>Aeromonas</i> spp., and FIB isolates cultivated from the two field-scale aquaculture systems, (FTS-A and FTS-B) over the respective experimental monitoring periods.....	59
Table 3.2. Molecular confirmation of presumptive <i>Aeromonas</i> spp. isolates and distribution of <i>Y. enterocolitica</i> and <i>Y. ruckeri</i> among screened isolates cultivated from FTS-A during seasonal sampling events.....	65
Table 3.3. Molecular confirmation of presumptive <i>Aeromonas</i> spp. isolates and distribution of <i>Y. enterocolitica</i> and <i>Y. ruckeri</i> among screened isolates cultivated from FTS-B during seasonal sampling events.....	66
Table 3.4. Frequency (%) of multiple drug resistance (MDR) in isolated pathogens <i>Yersinia</i> spp. and <i>Aeromonas</i> spp. from various locations within the local flow-through aquaculture system over two summer sampling events in June 2013 and May 2014.....	68
Table 4.1. Summary of the total number of <i>Yersinia</i> spp. and <i>Aeromonas</i> spp. isolated cultivated from the two pilot-scale recirculating systems, RAS-A and RAS-B over the respective experimental monitoring periods.....	90
Table 4.3. Molecular confirmation of presumptive <i>Aeromonas</i> spp. isolates and distribution of <i>Y. enterocolitica</i> and <i>Y. ruckeri</i> among screened isolates cultivated from the pilot-scale RAS utilizing NMB technology.....	97
Table 4.4. Molecular confirmation of presumptive <i>Aeromonas</i> spp. isolates and distribution of <i>Y. enterocolitica</i> and <i>Y. ruckeri</i> among screened isolates cultivated from the pilot-scale RAS utilizing UF technology.....	98
Table A1. Antibiotic Classes of Antibiotics Used in Phenotype Profiling.....	173

List of Abbreviations

ADA – Ampicillin Dextrin Agar

AM – Ampicillin

AMC – Amoxicillin

ABR – Antibiotic Resistance

APHA – American Public Health Association

ARB – Antibiotic Resistant Bacteria

AWCD – Average Well Colour Development

BHI – Brain Heart Infusion

CAZ – Ceftazidime

CFU – Colony Forming Unit

CIP – Ciprofloxacin

CLPP – Community-level physiological profiling

CLSI – Clinical and Laboratory Standards Institute

CRO – Ceftriaxone

CSUP – Carbon Source Utilization Pattern

CTX – Cefotaxime

DGGE – Denaturing Gradient Gel Electrophoresis

DNA – Deoxyribonucleic Acid

dNTP – Deoxyribonucleotide triphosphate

E. coli – Escherichia coli

FIB – Fecal Indicator Bacteria

FTS – Flow Through System

GC – Guanine Cytosine

HB – Heterotrophic Bacteria

HPC – Heterotrophic Plate Count

LBAS – Land-based Aquaculture System

MDR – Multiple Antibiotic Resistance

MF – Membrane Filtration

NMB – Nano-Membrane Bioreactor

OTC – Oxytetracycline

OTU – Operational Taxonomic Unit

PCR – Polymerase Chain Reaction

RAS – Recirculating Aquaculture System

rDNA – Ribosomal DNA

SXT – Sulfamethoxazole-trimethoprim

TAE – Tris-acetate-EDTA

UF – Ultra-filtration

VA – Vancomycin

VBNC – Viable but Non-Culturable

WHO – World Health Organization

YSA – *Yersinia* Selective Agar

Chapter 1: Introduction

1.1 Background

1.1.1 Global Aquaculture Practices

Recent decades have witnessed the rapid growth and development of aquaculture, defined as the farming of aquatic organisms, including fish, in response to the increasingly high worldwide per capita demand for fish and seafood production (van Rijn, 1996; Asche, 2010). The Food and Agriculture Organization of the United Nations (FAO) has predicted a 36% increase in the world population by 2030, but estimates only a 30% increase in production from marine capture fisheries until then (Ye, 1999). Currently, reports indicate that approximately 80% of worldwide marine fish stocks are considered overexploited or fully exploited (FAO, 2010). Evidently, in the absence of an effective and precautionary management of fisheries production and distribution, there is significant potential for depletion of fish stocks within global fresh and marine open waters. In an attempt to alleviate the pressure of fishing on marine stocks, and meet global demands left unmet by stagnant capture fisheries, it becomes necessary to fill the gap in production through intensive aquaculture practices (Tal *et al.*, 2009).

In 2006, aquaculture production capacity reached 51.7 million tonnes, valued at over 85.9 billion USD; (De Silva, 2012; FAO, 2010) a significant growth compared to the 1 million tonne production reported in the 1950s. Additionally, the FAO (2010) reports that aquacultures' contribution to global consumable fish supply is projected to increase to 60% by 2020, compared to the previous historical record of 47% in 2006. Internationally, the use of aquaculture has undeniable economic benefits and is a highly viable option for production of

food for rapidly growing populations.

As a result of the growing demand there has been rapid development of farms with intensive production. Typically, practices require human manipulation, but are able to operate with high densities of biomass. Within this category, a spectrum of different production methods exists, including on-shore (land-based) and offshore (coastal) operations (Figure 1.1). Coastal systems operate in open waters, both marine and freshwater, and are particularly tolerant to high production yield but can be associated with adverse environmental impacts (Blancheton *et al.*, 2013). For example, these offshore systems can deplete water quality, modify habitats, introduce exotic species and/or pathogens (Michaud *et al.*, 2006), tax energy and water resources, and chemically contaminate native waters (Naylor *et al.*, 2000). In contrast, land-based systems are generally considered a more ecologically sustainable alternative compared to offshore operations.

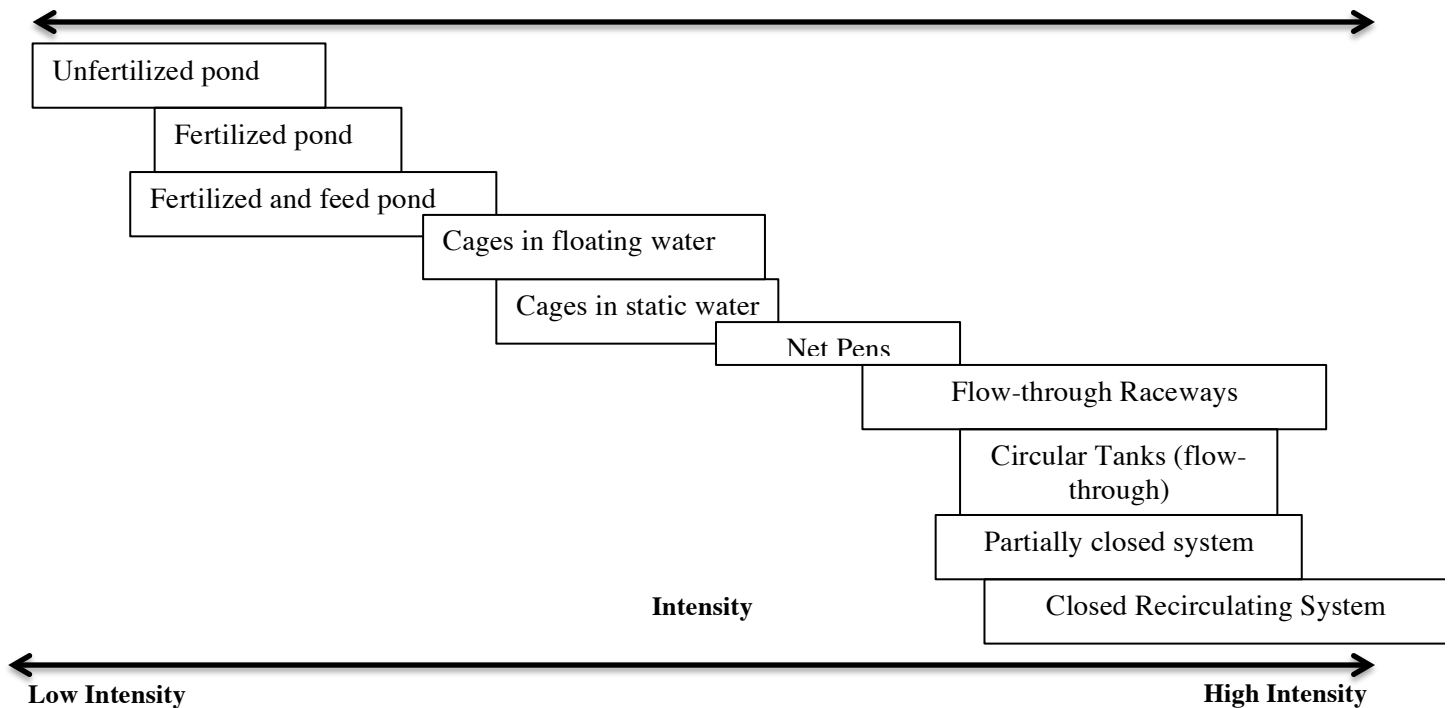

Figure 1.1. Spectrum of aquaculture production methods (adapted from Stickney, 1994).

1.1.2 Land-based Aquaculture Systems

In land-based aquaculture systems (LBAS), classification is based on specific criteria related to their engineering and design. Specifically, this incorporates hydraulic organization as a measure of the design of water exchange, and is expressed as "open" or "closed" (van Rijn, 1996). Both systems primarily consist of tanks (either above ground or in-ground) of different shape and manufacturing material, and are connected to water resources with the use of a pumping system. An open system (flow-through) involves discharge of water to a second water body (*i.e.* a pond or flowing system), and results in effluent discharge (Stickney, 1994). In this way, influent water is continuously pumped in, where it typically undergoes a single pass through rearing compartments before discharge to receiving water bodies. Conversely, closed systems typically utilize a means of treatment, which allows the system to re-use a large majority of influent water rather than discharging directly to the environment (Cottee and

Petersan, 2009). In order to ensure culture water quality remains adequate, small volumes (typically 10% of total volume) are regularly discharged to allow for additional input volume (van Rijn, 1996). These closed systems are typically referred to as recirculating aquaculture systems (RAS). It should be noted that a representative LBAS design may not be distinctly open or closed, instead, encompassing design elements of both incorporated into its engineering (*i.e.* a partial flow-through system).

Land-based operations have garnered recent widespread attention, due largely to their intrinsic advantages. Specifically, benefits include reduction in water consumption and land requirements, and the ability to store and treat accumulated waste products, while maintaining a high degree of control over production (van Rijn, 1996). This control is based on the ability to sequester waste and wastewater, which is not feasible in offshore operations. Consequently, this amplified control allows for minimization of wastewater production (associated particulate and soluble wastes) while managing associated microbial loads, contributing to the potential for ecological sustainability.

Effluent from these operations contains a multitude of constituents, and is typically characterized by waste elements such as feed derived solids and nutrients, fecal matter, chemicals, and pathogenic microorganisms (Snow *et al.*, 2012). A representative intensive flow-through operation will typically see effluent that is characterized by low-waste concentrations and a high-flow rate (Snow *et al.*, 2012). Despite the high-dilution factor as a result of a high-flow rate, the eventual discharge of waste and wastewater effluent from aquaculture practices can instigate detrimental changes in the receiving environment (Snow *et al.*, 2012). With respect to the flow-through operational design, the most common and evident negative impact is the degradation of downstream water quality, which may result from

uncontrolled discharge of the aforementioned waste products. In particular, downstream water quality impacts can be divided into physicochemical - which reflect instantaneous changes in environmental conditions, and biological, which reflect more gradual changes that occur in environmental conditions over time (Camargo, 1994). The exposure and potential accumulation of wastes in the receiving environment may cause long-lasting degradation as a result of chronic accumulation of contaminants, and is a serious and unwanted side effect of aquaculture practices.

Waste treatment prior to effluent discharge from a flow-through system is primarily done to mitigate any negative impacts on the receiving environment. Recirculating aquaculture systems focus on the management and treatment of these wastes for the purpose of providing adequate culture water quality, while reducing effluent discharge of solids and microbial loads (Snow *et al.*, 2012). Regardless of the type of aquaculture system, proper management of solids is typically facilitated by a system design comprised of a series of stages (Snow *et al.*, 2012). Cripps and Bergheim (2000) supported this idea, and described that an advanced aquaculture system design can integrate the stages, allowing for treatment to occur at each stage in the system. This represents the potential for development of environmentally friendly, optimized (*i.e.* high production rate, low cost) aquaculture practices for several aquaculture system types.

1.1.3 The Role of Microbial Communities within Aquaculture Systems

Our current understanding of the physiology and regulatory mechanisms of microorganisms has occurred as a result of our ability to remove and transport them from their natural, complex ecosystem into pure cultures. Grown under optimized laboratory conditions, this allows for study of these bacteria as individuals. The natural environment, however, rarely

provides these unicellular organisms with conditions optimal for their growth and reproduction. Instead, under environmental (non-laboratory) conditions, they differentiate into specialized cells that live in association with other microbial cells, forming populations that are capable of synchronized behaviour under certain conditions (Michaud *et al.*, 2009). Smaller populations will form networks with other populations, leading to an assemblage of multicellular communities that are better protected from the environment (Madigan and Martinko, 2006). Subsequently, the ecosystem can be defined by the "interaction of microbial communities with both macroorganisms and the greater environment" (Madigan and Martinko, 2006) (*i.e.* the biotic and abiotic environment). For the purpose of this thesis, the terms 'microbial community' or 'microorganisms' refers to the assortment of multi-species bacterial populations.

Bacteria within aquatic ecosystems were first recognized for their role in the decomposition of organic material, and remineralization of inorganic nutrients (Pomeroy *et al.*, 2007). It is now commonly understood that microorganisms within these environments are capable of strongly influencing nutrient fluxes through their interaction with dissolved organic matter and particulate organic matter (Blancheton, 2000). This fundamental concept underlying bacterial-organic matter interactions is also applicable to studies in aquaculture. As well as their role in nutrient fluxes, aquatic microorganisms play critical roles within aquaculture systems with regard to disease and water quality (Blancheton *et al.*, 2013). Many distinct microniches exist within a LBAS, serving to both facilitate and support the growth of a dynamic assemblage of diverse microbial populations. Within the controlled ecosystem of each aquaculture system, these communities are heavily influenced by various physico-chemical selective factors, (McQueen *et al.*, 1989) such as nutrient and organic carbon

availability, temperature, pH, oxidation-reduction potential, O₂ availability and turbidity (Kadlec, 1999; Mitsch and Gosselink, 2000). Moreover, each reared fish species and intake water supply introduces its own unique microbial flora (Blancheton *et al.*, 2013), leading to a source-induced variation in microbial diversity among each aquaculture system.

The majority of colonizing microbial species within aquaculture systems are likely benign or symbiotic, engaging in beneficial relationships with each other and/or the reared fish (Blancheton, 2000). It has been well documented that the microbial flora within an aquaculture system is comprised of both autotrophic and heterotrophic bacteria (Michaud *et al.*, 2009; Amann *et al.*, 1995) that are capable of oxidizing ammonia and the degradation of organic matter, respectively (Blancheton *et al.*, 2013). Fish feed utilized in aquaculture is rich in protein, and its breakdown results in a considerable amount of ammonium within the water (Kirchman, 1994). Ammonium is considered toxic to many life forms, including fish, and high levels will result in a change to water chemistry and enhanced incidence of mortality. Within the natural environment, this ammonium by-product is typically oxidized into nitrites and nitrates by nitrifying bacteria, and eventually reduced into nitrogen gas by denitrifying bacteria (Arrigo, 2005; Madigan and Martinko, 2006). A high organic load within culture waters promotes the ability of heterotrophic bacteria to outcompete nitrifiers, leading to an accumulation of ammonia in the water.

The role of heterotrophic bacteria within aquatic waters is well documented (Leonard *et al.*, 2002). These microorganisms comprise a vital part of the overall population, and contribute to factors such as oxygen consumption, production of metabolic byproducts, potential disease state in the fish, and competition with other microorganisms within the community (Leonard *et al.*, 2002; Blancheton *et al.*, 2013). Moreover, this heterotrophic

population is mainly comprised of 'neutral' bacteria that may function to maintain the water quality by dominating niches and suppressing the proliferation of detrimental pathogens (Attramadal *et al.*, 2012).

The waters within an aquaculture facility provide a unique environment in which antagonism among microbes naturally occurs. This phenomenon allows for the 'natural' reduction of pathogens through competition within the community, and is considered a means of biological control (Maeda *et al.* 1997). These diverse communities of microorganisms are known to harbor species that include both facultative and obligate pathogens, potentially compromising the health of the system and causing disease in the reared fish (Michaud *et al.*, 2009). The majority of these pathogens are considered ubiquitous in an aquaculture system, and may have suppressed virulence expression as a result of proper system management. Overall, it is well accepted that microbial inhabitants in aquaculture systems are immensely diverse and are implicated in the maintenance of a suitable and stable rearing environment.

1.1.4 Microbial Community Characterization within Aquaculture Systems

Investigation of the complexity of aquatic environments and various microbial populations proves to be a challenging task, largely due to the immense diversity of environmental populations, taxonomic ambiguity, and methodological limitations (Kirk *et al.*, 2004). Ritz *et al.* (1997) estimate aquatic environments may support 160 taxonomically unique species, allowing for numerous microbial interactions among species. As a result of this diversity and ecological complexity, researchers will often describe a microbial community in terms of measureable characteristics such as carbon metabolism and genetic structure (Kirk *et al.*, 2004). These characteristics are used to generate a "fingerprint" or unique "profile" of the community. Generally, investigation will employ an array of culture-based or molecular-based

methods to reveal community composition over space and time in response to environmental changes. These techniques rely on phenotypic or genetic patterns to determine which factors and resources govern the metabolic and genetic diversity in the aquatic environment.

Culture-based approaches include traditional plate counts, as well as community level physiological profiling (CLPP) (Kirk *et al.*, 2004). CLPP is the characterization of heterotrophic microbial communities based on sole carbon source utilization patterns (CSUPs) (Lehman *et al.*, 1995) and has been successfully applied to study the potential metabolic diversity of microbial communities from a range of environments, including soil and aquatic ecosystems (Garland, 1997; Weber *et al.*, 2008; Weber and Legge, 2010).

Molecular-based techniques for profiling include polymerase chain reaction (PCR) and denaturing gradient gel electrophoresis (DGGE). This approach involves the use of genes coding for ribosomal RNAs, which are among the most conserved macromolecules in living systems (Atlas and Bartha, 1998). In prokaryotes, rRNA genes are arranged in operons and microorganisms may contain one to fifteen of these operons within their genomes (Louws *et al.*, 1999). DNA isolated from environmental samples contains a high amount of evolutionary and phylogenetic information. Particularly useful for phylogenetic microbial studies is the use of highly conserved and slowly mutating genes (Atlas and Bartha, 1998). The small subunit ribosomal RNA (ss rRNA) gene is universally present (minimum single copy) in all prokaryotes (16S) (Head *et al.*, 1998) and has a mosaic structure of highly conserved regions interspersed with hypervariable regions. This permits for a primer design that is targeted to a high diversity of organisms, while containing a large amount of phylogenetic information. Specifically, by using PCR to amplify regions of the 16S rRNA gene with universal primers complementary to the highly conserved regions, areas of hypervariability are also amplified.

This results in generation of amplicons that exhibit a high degree of specificity for bacteria within a sample (Amann *et al.*, 1995). The ubiquity, genetic stability (low polymorphism rate), and high copy number makes this gene an ideal molecular marker for microbial characterization studies and can be used to characterize phylogenetic relationships and taxonomically characterize microorganisms from aquatic sources (Wright *et al.*, 2004).

Culture-based approaches coupled with molecular techniques are used to answer fundamental questions concerning structural composition (*i.e.* what types of microorganisms are there) and functional abilities (*i.e.* what do they do) to explain the roles of microorganisms in relation to ecosystem function (*i.e.* remediation, biogeochemical cycling, etc.) (Kadlec, 1999). Regardless of techniques used, comprehensive characterization of the microbial communities within aquaculture systems requires reliable, accurate detection and quantification of environmental microorganisms.

1.1.5 Pathogenic Microorganisms Associated with Rearing Practices

Taxonomic studies identify the phenomena that several representatives of many bacterial taxa have, at some point in history, been associated with disease in fish and other marine animals (Cottee and Petersan, 2009). It is important to consider that not all of these bacteria constitute what is known as an obligate pathogen. Instead, Blancheton *et al.* (2013) report that the majority of disease outbreaks in aquaculture systems may be triggered by opportunistic microorganisms that become pathogenic when host immune resistance is lowered, typically as a result of environmental stress factors or over-colonization. The proliferation of these opportunistic microbial pathogens is generally promoted in unstable environments, where uncolonized niches and high organic matter substrate support rapid

growth. According to the ecological *r/K-theory* (MacArthur and Wilson, 1967), rapidly growing opportunists (termed r-strategists) will be the first to initially exploit and increase in available substrate supply in a perturbed or unpredictable environment where there is little competition. Conversely, k-strategists are typically slow growing specialists that compete better in the presence of limited resources, and are favoured in more stable environments (*i.e.* an environment where there is little fluctuation in availability of resources such as dissolved organic matter for heterotrophs). A more comprehensive understanding of these multifaceted microbial interactions in aquaculture systems is necessary in order to develop functional tools for pathogen control, attenuation, and system maintenance.

Both raw and treated wastewaters from aquaculture systems are recognized sources of several species of pathogenic microorganisms (Crocket, 2007). Major pathogens identified in infection outbreaks include the Gram-negative bacteria *Yersinia* spp. and *Aeromonas* spp. and are the etiological agents of enteric red mouth disease and furunculosis, respectively (Dahiya and Stevenson, 2010; Stevenson, 1999; del Cerro *et al.*, 2002). These pathologies are recognized worldwide, and may contribute to substantial fish mortality percentage and economic loss.

Currently, species of *Aeromonas* are widely recognized as causative agents of a spectrum of diseases in both animals and humans (Ghenghesh *et al.* 2008). Previous studies have revealed that several motile *Aeromonas* species are becoming food and waterborne pathogens (both strict and opportunistic) of increasing importance (Araújo *et al.*, 2002; Ansari *et al.*, 2011). Historically, members of this genus have been associated with several food-borne outbreaks, and more recently have become more frequently isolated from patients with traveler's diarrhea (von Graevenitz, 2007). In particular, *Aeromonas salmonicida* and

Aeromonas hydrophila have been documented as the causative agents of furunculosis, ulcerative disease, hemorrhagic disease, red sore disease, and septicemia in fish (Austin, 2009). Currently, as a putatively emerging enteric pathogen, *Aeromonas* species have demonstrated the inherent capability to grow in water distribution systems, especially in biofilms, where they may be resistant to disinfection and removal (Chauret *et al.*, 2001). For these reasons, further investigation of the presence and pathogenicity should be conducted regarding this genus in aquaculture systems. This is especially important with regard to the possibility for transmission to humans (via ingestion of contaminated product), as well as to the receiving environment (in the case of the flow-through systems).

Surveillance data indicate a global distribution of several species of *Yersinia*, accompanied by an extensive increase in the number of non-outbreak-related isolates and cases of yersiniosis reported during the last two decades (Wannet *et al.*, 2001). In particular, *Yersinia enterocolitica* is associated with animal hosts (such as fish) and is shed in the feces of infected animals (Bottone, 1999), leading to its significance as an enteric bacterium that has been identified as a potential waterborne human pathogen (Theron *et al.*, 2002; Sharma *et al.*, 2003). Of additional importance are the *Yersinia* species *Yersinia pseudotuberculosis* and *Yersinia pestis*, which have historically been known to cause human disease (Bottone, 1999). Overall, while most attention in literature has focused on these three species, several other, less familiar *Yersinia* species have been documented to exist. These remaining eight species, identified as *Y. aldovae*, *Y. bercovieri*, *Y. frederiksenii*, *Y. kristensenii*, *Y. intermedia*, *Y. mollaretii*, *Y. rohdei*, and *Y. ruckeri*, have not been as comprehensively studied. Due to the absence of classical *Yersinia* virulence markers, these species are generally considered to be environmental and non-pathogenic species, and have been successfully isolated from freshwater (Massa *et al.*,

1988), sewage (Ruhle *et al.*, 1990), and drinking water (Kuznetsov and Timchenko, 1998).

Antibiotic Resistance in Pathogens Associated with Aquaculture Practices

Prolonged and excessive use of antibiotics has been previously reported as a major factor leading to the development of antibiotic resistant bacterial strains (Dixon, 2000). However, the concern with antibiotic resistance in freshwater aquaculture systems has only recently gained recognition. As a result, it is still somewhat poorly documented in literature, especially with regard to the microbial community influence on resistance development in waterborne pathogens in these highly industrious aquaculture systems (Schmidt *et al.*, 2000). In aquatic environments, such as aquaculture systems, antibiotics are quickly diluted as a result of water flow and persist at sub-lethal concentrations within the environment, exerting a weak but constant selection pressure. This non-lethal selection significantly enhances the probability for physiologically fit and stable strains to develop. Resistance is often associated with a fitness cost to the microorganisms, which in theory, should lead to the attenuation of resistant strains following cessation of antibiotic use. However, compensatory genetic evolution has been shown to rapidly reduce the accompanying fitness cost, decreasing the probability of resistance disappearance (Andersson and Hughes, 2011). For instance, a study by Perron *et al.* (2012), reported that frequent bacterial recombination through the uptake of foreign genetic material was enhanced within functionally diverse communities, and may in fact be more advantageous for bacterial survival because it facilitates the creation of high fitness genotypes more rapidly than by point mutation alone. Moreover, recombination may enable the purging of deleterious mutations from bacterial populations, thereby preventing a dramatic decrease in fitness (Gagneux *et al.*, 2006). Our current understanding of bacteria indicates that solitary microbial species are rarely found in natural environments, and instead exist in communities of

dozens to thousands of microbial species (Madigan and Martinko, 2006). The ubiquity and diversity of community constituents is likely a critical driving factor influencing antibiotic resistance, and should not be disregarded.

1.1.6 Wastewater Treatment Approaches

The management, treatment, and reuse of wastewater are of great importance when considering both human and animal health, along with environmental protection. Adequate removal of contaminants is considered the cornerstone of wastewater treatment. Primary pollutants from aquaculture operations, as described by Ackefors and Enel (1990) include uneaten feed and feed-derived solids, nutrients, fecal matter/excretion products, and pathogenic microorganisms.

Wastewater treatment in flow-through systems is motivated by the need to discharge higher quality effluent in an effort to reduce the potential negative impact on the receiving ecosystem. In re-use or recirculating systems, waste removal and management is required to maintain adequate culture water quality. Additionally, in order to minimize accumulation of deleterious wastes, some water exchange via the inflow of source water, and subsequent discharge of effluent is necessary even in the most efficient RAS (Twarowska *et al.*, 1997)

Regardless of motivation, the treatment of waste within LBAS may be facilitated by several steps of filtration, which are primarily divided into mechanical and biological filtration (Blancheton *et al.*, 2013). The former utilize mechanical processes to promote separation and removal of suspended solids [SS] (including particulate organic matter) from culture water, resulting in a drastic removal of particulate matter and waste substances (Losordo *et al.*, 1998), while the latter relies on the biological oxidation and redox reactions carried out by microbial communities as a consequence of nutrient input (fish waste output and SS). As such, these

biological filtration methods are less easily controlled, but play a significant role in wastewater treatment.

The development and maintenance of an efficient, productive, biologically secure and disease free LBAS requires a comprehensive understanding of all processes involved in treatment, both mechanical and biological (oxygen, temperature, ozonation, UV, pH, and salinity) to the biological filtration systems.

Mechanical Filtration

Management of particulate matter in culture water consists of rapid elimination of suspended and sedimentable materials, but as particle size decreases, efficiency of solids removal via physical processes decreases, leading to an increase in biofouling (Glucina *et al.*, 2000). The method of solids waste removal from culture water is, therefore, largely dependent on the type and size of solid being removed. Larger particles can be removed via sedimentation, a process based on the principle that particulate wastes $<100\mu\text{m}$ will settle to the bottom of the tank as a result of gravitational forces (von Sperling and de Lemos Chernicharo, 2005). Accumulated solids can then be removed with the aid of tools such as a sump pump (Stickney, 1994). In contrast, mechanical filtration is often used to remove smaller or finer particles suspended in the water column. These removal systems function to "screen" suspended particles from culture water, effectively decreasing the particulate matter load. The sizes of removable particles are largely dependent on the pore size of the screen or sieve, and can be tailored for desired content removal.

One example of a mechanical process is membrane filtration, which is a pressure driven process that physically separates solids from a fluid medium with the use of semi-permeable membranes (Madaeni, 1999). Specifically, membrane filtration processes include

microfiltration, ultrafiltration, nanofiltration and reverse osmosis, which are classified based on membrane pore size (Madaeni, 1999; Peters, 2010). The pore size of ultrafiltration membranes ranges between 0.005 to 0.02 μm (Madaeni, 1999; Peters, 2010), which allows the diffusion of dissolved components and water (permeate) while retaining suspended particles, protozoa, bacteria, viruses and other waste components (retentate) larger than the applied pore size (Guo *et al.*, 2009). Overall, the selection of membrane filtration type is dependent on the individual removal requirements for a system.

Biological Filtration and Biofilm Development

While mechanical processes used for wastewater treatment in LBAS can be monitored and managed, biological filtration systems based on the interaction of microbial communities among themselves and with their environment (Leonard *et al.*, 2002), are not easily controlled. A central characteristic of LBAS architecture and wastewater treatment is the use of biological filters. Principally, these consist of a bioreactor containing substrates of various materials (media) designed to allow for maximal surface area contact with culture water in order to promote growth of bacterial communities on the bioreactor media (Gutierrez-Wing and Malone, 2006). The microbial composition of these filters has only become more thoroughly understood within the last decade (Gutierrez-Wing and Malone, 2006). Early studies focused on traditional culturing and enrichment techniques, which are highly biased towards the <1 % of microbial species able to grow under standard laboratory conditions (Schreier *et al.*, 2010). More recently, molecular-based tools have permitted the evaluation of microbial diversity in these assemblages, providing a deeper insight into the biological activities and community interactions.

Microorganisms can be found freely floating in the water flow (planktonic phase), or

living in complex aggregations characterized by the presence of a protective and adhesive matrix, termed a biofilm (Leonard, 2000; Michaud *et al.*, 2009). It is well accepted that bacteria in aquatic environments will readily adhere to any provided solid support that is in contact with water (Lewandowski *et al.*, 1993; MacDonald and Brazel, 2000). Zhu and Chen (2001) define a biofilm as a "viscoelastic layer of microorganisms" that represents a water-substrate interface and site of active metabolic exchange. The protective extracellular polymeric matrix limits competition for essential substances from microorganisms outside the biofilm, and the spatial heterogeneity has a substantial impact on the behaviour and functionality of the biofilm (Leonard, 2000).

For their operation, biofilters used in LBAS exploit the biological aerobic and anaerobic processes for elimination of waste products such as nitrogen (ammonia excreted by fish) and carbon (from uneaten feed and fecal matter) present in culture water (Schreier *et al.*, 2010) by both autotrophic and heterotrophic bacteria. The filters are dimensioned according to the amount of substrate (m^3) they can contain, or the total area (m^2/m^3) provided by the substrate material used (Drennan *et al.*, 2005). A larger surface area within the biofilter supports a larger biofilm and an increase in the number microorganisms capable of efficient chemical conversion of waste, thereby supporting a denser fish rearing population. The literature concerning the mechanisms and use of biofilters in aquaculture systems is steadily increasing, and more research is warranted concerning this treatment approach in highly intensive land-based aquaculture operations.

1.2 Research Need and Thesis Objectives

The growing worldwide demand for fish production has prompted research towards intensive aquaculture. Innovative system designs, such as recirculating and flow-through

aquaculture systems, have been developed to improve the efficiency and sustainability of intensive aquaculture practices. These LBAS systems exhibit a wide range of spatial and temporal heterogeneity. Although such heterogeneity suggests the potential for culture water to support a diverse and spatially complex assortment of microorganisms, there is a lack of information regarding the overall diversity and composition of microbial communities (including pathogens) in the different compartments of these systems. An in-depth analysis of these communities will provide quantitative and qualitative outputs, which may serve to generate a comprehensive definition of the ‘standard’ microbiome of a LBAS. Furthermore, this information can enhance our ability to better understand the presence and potential persistence of pathogenic microorganisms, particularly following treatment optimization strategies. Considering the wide array of parameters that are responsible for microbial community structure (*i.e.* input source water quality, nutrient availability, feeding regime, biofilm formation, potential microbial competition, microniche availability, and wastewater treatment technology) the identification of the significance of each factor can increase our knowledge as to the primary mechanisms governing the microbial ecology of these freshwater systems. This will promote better control of the microbial quality of culture water and reduce incidences of disease outbreak. Given the evidence provided within this chapter, it was hypothesized that there would be evident differences in microbial community composition as a consequence of the greater spatial and temporal variability expected between differently engineered LBAS. Additionally, it was hypothesized that both pathogen presence and treatment technology would impart a discernable impact on the metabolic and genetic profiles of these systems.

The overarching goal of this thesis was to characterize the structural and functional

characteristics of predominant microbial communities in LBAS of both flow-through and recirculating design, in order to better understand the microbial community response to spatial and temporal variability within aquatic environments. This information is important in relation to the ongoing expansion of intensive land-based aquaculture practices, and will contribute to the development of efficient and targeted management strategies in these highly productive systems.

In order to address the principal research objectives, the following supporting objectives were investigated:

- 1) Characterize the presence and abundance of select microorganisms within differing aquaculture environments using a traditional microbiological media-based approach, including: heterotrophic bacteria counts, classical fecal indicator organisms *E. coli* and *Enterococcus* spp., and relevant fish pathogens *Yersinia* spp. and *Aeromonas* spp. This also involved an investigation of the factors contributing to the occurrence and persistence of pathogens within each system.
- 2) Confirm cultureable *Yersinia* spp., *Aeromonas* spp. presumptive isolates using molecular techniques (qualitative PCR), and further distinguish *Yersinia* spp. isolates between two common strains; *Y. ruckeri* and *Y. enterocolitica*, using species-specific PCR.
- 3) Investigate the impact of different wastewater treatment technology approaches on the structure and function of microbial communities within recirculating aquaculture systems. The influence of technology approach on the removal or persistence of pathogenic bacteria within the system was also investigated.
- 4) Determine the antibiotic resistance profiles of environmental fish pathogens *Yersinia*

spp. and *Aeromonas* spp. isolated from a local flow-through aquaculture system against a panel of clinically relevant antibiotics using phenotypic detection techniques.

Chapter 2: Materials and Methods

2.1 Overview of Experimental Approach

The knowledge of microbial community composition and structure is central to many ecological and environmental studies. The particular interest in better understanding the communities in aquatic environments likely stems from the knowledge that microorganisms play vital roles in regulating nutrient transformations, degrading contaminants, and maintaining structural and hydrological properties. Kirk *et al.* (2004) support the concept that the characterization of these communities has proven to be challenging for microbial ecologists, often related to factors such as the immense diversity of microbial populations, taxonomic ambiguity, and methodological limitations. Nonetheless, the characterization of environmental microbial communities has become increasingly successful by combining phenotypic (culture-based) and genotypic (molecular-based) microbiological methods. A multiphasic, integrative approach that employs these complementary methodologies was utilized in an effort to comprehensively evaluate the structure, function, and adaptation within potential composition profile of communities in land-based aquaculture systems of varying scale and design. In particular, it has been recognized that cultureable bacteria play critical roles in environmental processes and need to be regarded as a vital component of the community. In light of this, community level physiological profiling (CLPP) was used to provide a characterization of the community through the assessment of the metabolic function and potential of the cultureable community. Additionally, traditional plate-count techniques were utilized to investigate the presence and persistence of select organisms of interest. As part of the multi-level approach, and in an attempt to eliminate cultivation bias, the molecular-based technique of denaturing gradient gel electrophoresis (DGGE) allowed for the generation

of DNA-based "genetic fingerprints" by separating PCR amplified fragments that represented functional community genes. In summary, profiling of communities was accomplished at the species, community, and genomic level.

2.2 Site Descriptions and Sampling Protocols

In an effort to gain a more thorough understanding of microbial communities in aquaculture systems of varying scale and design, two pilot-scale recirculating and two field-scale flow-through aquaculture systems were selected for sampling. Sites were selected in part according to design, accessibility and size. All water samples collected were sampled from 5-10 cm below the water surface using sterile materials. In this thesis, each pilot-scale RAS and field-scale FTS are coded alphabetically, and herein referred to as RAS-A, RAS-B and FTS-A, FTS-B.

FTS-A: Northern Field-Scale Flow-Through Aquaculture System

This FTS is located in a rural northern setting in Coldwater, ON, Canada. Influent water is pumped from a series of on-site metered wells, with effluent water the same as metered influent rates, at an approximate rate of 1.8-1.9 million liters of water per 24 hours. Influent water is pumped to an indoor early rearing facility, which consists of a series of rearing tanks and raceways for intensive production. Water enters the system from the wells and is pumped in a single pass over early rearing tanks, after which it is pumped in a single pass through a solids removal drum filter. Following passage through the drum filter, water is then pumped to indoor raceways for a single pass before discharge to a series of treatment ponds, including a main treatment pond and 2 other contingency/polishing ponds, after which treated water is discharged to an unnamed tributary to the Coldwater River. Collected solids from the drum filter, as well as settled solids from rearing tanks are removed and discharged to

the treatment pond.

FTS-B: Local Field-Scale Flow-Through Aquaculture System

The FTS-B is located in a rural setting in New Dundee, ON, Canada. It is a privately run operation, with property spanning over 20 acres. It is primarily a flow-through system, where influent water is derived from a series of on-site wells (groundwater), as well as from an on-site pond containing fish of various species. The pond is stocked yearly (spring) with fish (*species unknown*), and is used for commercial spring/summer/autumn public fishing. Influent water sources are pumped to a series of indoor early rearing tanks, after which water flows to an outdoor raceway and final holding compartment prior to discharge to a stream that connects to the Nith River. For a schematic of the overall system design, please refer to the Appendix, Figure A1.

Pilot-Scale Recirculating Aquaculture Systems

Research was conducted at a field-scale recirculating site located on the property of Fleming College in Lindsay, ON, Canada. This system was chosen due to its recirculating design, which presented a unique opportunity to investigate the microbial community within a closed system exposed to intensive rearing operations and re-use of culture water. Wastewater from overall rearing operations, including six above-ground rearing tanks, was collected in a main filtration tank, after which two pressurized side-streams were diverted to supply two pilot-scale recirculating systems with the same quality of influent wastewater. Each pilot-scale system was outfitted with a single treatment technology for investigation, either a nano-membrane biological reactor or membrane filtration technology. This allowed for an investigation and assessment of the spatial and temporal variation between microbial communities exposed to treatment technology in a RAS.

RAS-A: Nano-Membrane Treated System

RAS-A was fitted with a nano-membrane bioreactor (NMB) technology, provided by BioGill™ (BioGill Operations Pty Ltd., NSW, Australia). The NMB is an above ground, non-submerged, nano-ceramic/nano-particulate membrane bioreactor. Its design is different from typical membrane bioreactors, in that it is not a trans membrane filtration system. Rather, it consists of a series of “gills”; each composed of a pair of membranes that define an inner region (lumen) through which water trickles. Nutrients in the liquid phase diffuse through the porous membranes to a biofilm that grows on the outer faces of the membranes, which are in direct contact with air. As such, the NMB is a combination of solid-state and liquid-state culture. Aeration is passive in the NMB, utilizing convection of the ambient atmosphere. Operating as a batch-system, the typical treatment cycle for the influent water involved multiple passes of the liquid over the nano-ceramic membranes during a 24 hr period, after which treated water was released from the outlet and pumped to a 20L holding tank reservoir before recirculation to the rearing tanks. A schematic of the technology design and treatment mechanism is provided in the Appendix, Figure A2.

RAS-B: Ultrafiltration Treated System

RAS-B was fitted with an ultrafiltration (UF) membrane technology, provided by SkyJuice™ (SkyJuice Foundation, NSW, Australia). The UF (Appendix, Figure A2) comprises a single MEMCOR© membrane sub-module located inside a low-pressure housing. Raw water (influent) flows along the length of the hollow fibres with a water head pressure of 6 psi, and is forced through the pores of the fibre (0.05 µm) to produce a filtrate. The unit

contains a pressure release valve to ensure the pressure to the UF is maintained at the operational design pressure of 6 psi. Excess water associated with pressures higher than 6 psi was diverted back into the original location of the source water. Following filtration, the filtrate was diverted to a smaller holding reservoir (holding tank). This reservoir was operated as a flow-through tank with the filtrate eventually being diverted back to the rearing tanks of the RAS. A schematic of the technology design is provided in the Appendix, Figure A3.

2.2.1 Sampling Regimens

FTS-A: Northern Field-Scale Flow-Through Aquaculture System

Samples were collected using 500 mL or 1000mL sterilized polycarbonate bottles, and were immediately placed in a cooler at 4°C and shipped from Lindsay, ON to arrive at Wilfrid Laurier University within hours. A total of 4 samples were collected on each sampling date; February 10th, August 14th, and November 12th, 2013 and April 23rd, 2014, resulting in a total of 16 samples from FTS-A. Sample points are referred to as Well Water, taken from the series of on-site wells supplying the flow-through system; Raceway, taken from single-pass water within a raceway containing reared fish; Treatment Pond, taken from the on-site outdoor pond containing discharged rearing water and waste material, and Polishing Pond, which is the last of the on-site treatment ponds prior to discharge to the receiving environment.

FTS-B: Local Field-Scale Flow-Through Aquaculture System

Samples were collected using 500 mL or 1000mL sterilized polycarbonate bottles, and were immediately placed in a cooler at 4°C and immediately transported back to Wilfrid Laurier University for immediate processing upon arrival in lab. A total of 8 samples were collected on two separate summer season sampling dates. Specifically 4 samples were obtained

during each event on June 18th 2013 and May 13th, 2014. Sample points are referred to in this thesis as Well Water, taken from the convergence point of all inflowing on-site well water being pumped into the system; Pond water, taken from the location in the on-site pond where water is pumped to the system; Early Rear, taken from a series of rearing tanks containing juvenile (fingerling) reared fish, and Discharge Effluent, taken from the system compartment where all rearing water converges prior to release to the receiving environment.

RAS-A: Nano-Membrane Bioreactor Treated System

Samples were collected using 500 mL or 1000mL sterilized polycarbonate bottles, and were immediately placed in a cooler at 4°C and shipped from Lindsay, ON to arrive at Wilfrid Laurier University within hours. A total of 26 samples from RAS-A were collected over an experimental monitoring period of 16-weeks, between the months of February 2014 and May 2014. Specifically, samples were obtained on Feb. 6th; 20th; Mar. 4th; 18th; 24th; Apr. 1st; 21st and May 6th; 22nd. For ease of results and discussion, sampling events are herein referred to by the sampling week (W1-W16), although the sampling month is also provided.

It should be noted that biofilm sample results are absent for the March 18th sampling date, as the sample was contaminated during transport, rendering it unusable for examination. Sample points are referred to as Influent, taken from the inflowing water to the pilot-scale system originating from the RAS; Biofilm, taken from the internal compartment of the bioreactor; and Effluent, taken from the discharge water exiting the bioreactor following a batch holding period of 24 hrs.

RAS-B: Ultra-Filtration Treated System

Samples were collected using 500 mL or 1000mL sterilized polycarbonate bottles, and were immediately placed in a cooler at 4°C and shipped from Lindsay, ON to arrive at Wilfrid Laurier University within hours. A total of 27 samples from the UFTS were collected over a 16-week experimental monitoring period, between the months of February and May 2014, and specifically on Feb. 6th, 20th; Mar. 4th, 18th, 24th; Apr. 1st, 21st and May 6th, 22nd. It should be noted that locations sampled varied throughout the monitoring period. However, the multiple sampling events throughout the entirety of the monitoring period do result in consistency of points sampled. Sample points are referred to as Source Water, taken from the inflowing water to the pilot-scale system originating from the RAS (effluent RAS water). This water has been in contact with the fish sufficiently long enough to reflect at a minimum a low concentration of fish waste (dissolved and particulate), while being sufficiently dilute enough to not prematurely clog the ultrafiltration unit; Source Bioballs, taken from inflowing water from the RAS and containing approximately six filter media (Bioballs™) which had been suspended within inflowing water for biofilm attachment; After Pre-Filter (APF), taken from water that had passed through a pre-filter to remove large suspended particles ($\leq 500\mu\text{m}$); After Ultra-Filter (AUF), taken from filtrate that had passed through the ultrafiltration unit; Biofilm Tank Bioballs (BT), taken from filtrate within tank reservoir and suspended Bioball™ filter media; and Backwash Port (BP), taken from backwash water following manual cleaning of ultrafiltration unit membrane core.

2.3 Characterization of the Microbial Community and Environmental Pathogens

2.3.1 Culture-Based Methods

Suspended Substrate Media Detachment Protocol

The basis for the detachment protocol used was adapted from methods employed by Grove *et al.* (2004). For detachment of microbial biomass from suspended substratum samples, sample bottles containing removed substrate media were subjected to sonication at 55kHz for 1 to 2 mins using a Branson® CPX Ultrasonic Cleaning Bath (Branson, Danbury, CT, USA) and resulting water suspension was used for respective culture-based microbiological plating methods.

2.3.1.1 Heterotrophic Plate Counts

Heterotrophic plate counts (HPCs) are considered a classical microbiological technique used to measure the microbial flora within water or other media types requiring an external source of organic nutrients for growth (organisms typically termed heterotrophs) (Allen *et al.*, 2004). HPCs are traditionally used to measure the bacteriological quality of a water source based on colony forming units (CFUs). In this study, the HPC method was employed to monitor the overall health of microorganisms within the aquaculture systems in consideration over the duration of the experimental monitoring period.

The HPC procedure was performed according to the standard method as described by APHA (1998). Following the creation of a 10^0 to 10^7 dilution series using 9 mL of sodium-free phosphate buffer, 100 μ L from each dilution was spread, in duplicate, onto R2A agar (BD Difco, Fisher Scientific, Whitby, ON). HPCs were counted following 5 to 7 days of incubation at room temperature, where plates with less than 30 or more than 300 colonies were considered statistically invalid and excluded from CFU per mL calculations.

2.3.1.2 Recovery, isolation and enumeration of select environmental pathogens

Cultivable *Yersinia* spp. and *Aeromonas* spp. were isolated from each interstitial water sample according to standard methods for the examination of water and wastewater, where standard spread plate methods were employed for enumeration of *Yersinia* spp. and the membrane filtration method was employed for the enumeration of *Aeromonas* spp., as outlined by the American Public Health Association (APHA, 1998).

Due to the prevalence of high numbers of background flora present in environmental samples, and the typically low number of pathogenic strains of *Yersinia* spp., direct isolation even on selective media is seldom successful (Bockemühl and Wong, 2003). The recovery of cultivable *Yersinia* spp. is contingent upon a number of factors, including - the level of competing background flora present in the environmental sample, the numbers of pathogenic and nonpathogenic *Yersinia* spp. present, and state of physiological activity of species (Hench *et al.*, 2003). Additionally, a recovery method that yields high recovery of one species of *Yersinia* may not be suited to other species. Therefore, a tailored approach was required, involving a series of nonselective pre-enrichment and selective media plating in order to successfully isolate and enumerate the greatest multitude of *Yersinia* spp. from environmental samples (Bockemühl and Wong, 2003). All bacteriological media were obtained from BD Difco™ (Mississauga, ON), unless otherwise stated. For initial non-selective pre-enrichment of *Yersinia* spp., 10 mL of sample water was inoculated into 90 mL of 10X buffered peptone water (BPW) and incubated in a lab-line incubator-shaker (Fisher Scientific, Whitby, ON, Canada) at 25°C for 48 hr with agitation at 150 rpm. BPW is a non-inhibitory medium, which favours the recovery of *Yersinia* spp. from a state of physiological inactivity or trauma that may have been caused by freezing, heat, desiccation, high osmotic pressure or drastic

temperature change. This broth medium is rich in nutrients, and produces high resuscitation/recovery rates for sublethally damaged bacteria and helps to support intense growth (BD™, 2011).

Following pre-enrichment, appropriate bacterial concentrations/suspensions were achieved by serial 10-fold dilutions (10^0 - 10^{-7}) in 0.85% sterile saline (NaCl). To enumerate the bacteria, 100µL aliquots were spread, in duplicate, onto *Yersinia* selective agar containing *Yersinia* antimicrobial supplement CN (Cefsulodin-Novobiocin) for *Yersinia* spp. (Hench *et al.*, 2003) and incubated at 35°C for 24 hr. *Yersinia* Selective Agar (YSA) is a differential selective medium for the isolation and enumeration of *Yersinia enterocolitica* from environmental samples. Due to its selective and differential components, including sodium desoxycholate and crystal violet, and the antimicrobial agents Irgasan, novobiocin, and cefsulodin, YSA may also be used for the isolation of other species of *Yersinia* which may be present in aquatic environments, including *Y. pseudotuberculosis*, *Y. intermedia*, and *Y. frederiksenii* (Bockemühl and Wong, 2003). *Yersinia* are able to ferment mannitol in the presence of neutral red, yielding an intense, localized acid production in the centre of the colony, giving the appearance of a deep red 'bull's eye', surrounded by a transparent, pale border. The colony size, smoothness and the ratio of the border to centre diameter may vary considerably among environmental serotypes. Characteristic *Yersinia* spp. colonies were recorded (and calculated in CFUs per 100 mL) and further streaked for purity and isolation onto Brain Heart Infusion (BHI) agar and incubated at 35°C for 24 hr, after which they were kept at 4°C for short-term storage until further analysis.

For *Aeromonas* spp., 15 mL of site sample water was filtered through a 0.45 µm, 47 mm mixed cellulose ester filter, and then aseptically transferred onto ampicillin dextrin agar

(ADA) supplemented with ampicillin dextrin selective supplement (2.5 mg/ 500 mL) for the recovery of *Aeromonas* spp. isolates. ADA is used for the differential and selective isolation and enumeration of *Aeromonas* species in water by the membrane filtration technique. Tryptose and yeast extract within the media provide nitrogenous compounds, along with other essential nutrients for growth of *Aeromonas* spp. Additionally, sodium chloride maintains the osmotic balance of the medium. Plates were incubated for 24 hr at 35°C and positive colony characteristics of *Aeromonas* spp. were indicated by the presence of yellow colonies generated from the production of acid from dextrin fermentation, as indicated by colour change from blue to yellow by the pH indicator, bromothymol blue. Characteristic colonies were then recorded (and calculated in CFU/100 mL) and further streaked for purity onto BHI agar and incubated at 35°C for 24 hr, after which they were kept at 4°C for storage until further analysis.

2.3.1.3 Isolation and enumeration of water quality indicator organisms

Enterococcus spp. and *E. coli* were isolated from all provided interstitial water samples using the standard membrane filtration methods as outlined by the American Public Health Association (APHA, 1998). From the original samples, 10-fold dilutions of 10^{-1} and 10^{-2} were made, and these, as well as 1mL and 10mL of the samples were filtered through gridded 0.45 μm , 47 mm mixed cellulose ester filters (Difco, Fisher Scientific, Ottawa, ON) with the aid of a vacuum pump. Subsequently, filters were placed onto 47 mm selective agar plates; mEnterococcus agar and mFC-BCIG agar for the quantitative recovery of *Enterococcus* spp. and *E. coli*, respectively (Difco, Fisher Scientific). In order to account for positive and negative colony presentation, 100 μL of *E. coli* (ATCC 12292) and *Enterococcus faecalis* (ATCC 49532) were filtered and plated onto respective media types. The preparation of mFC-

BCIG agar was made by supplementing mFC basal agar with 100µg/L of 5-bromo-4-chloro-3-indolyl β-D-glucuronide cyclohexyl ammonium salt (Medox Diagnostics, Ottawa, ON, Canada) for the chromogenic differentiation of *E. coli* from other fecal coliforms in the sample. mFC-BCIG agar plates were incubated at 44± 0.5°C for 24hrs in a hot water bath and mEnterococcus agar plates were incubated at 35±2°C for 48hrs. Colonies obtained from the mEnterococcus agar plates were confirmed by transferring the filter to a pre-warmed bile esculin agar (Difco, Fisher Scientific) and incubating at 44°C for 2hrs. Dark brown colonies on BEA were considered presumptive *Enterococcus* spp. and blue colonies on mFC-BCIG agar plates were considered presumptive *E. coli*. Individual colonies of *Enterococcus* spp. and *E. coli* were then plated onto prepared brain heart infusion (BHI) and LB agar, respectively, for storage at 4°C until further analysis.

2.3.1.4 Antibiotic Resistance Profiling

Antibiotic susceptibility was assessed for presumptive *E. coli*, *Enterococcus* spp., *Yersinia* spp., and *Aeromonas* spp. isolates using the Kirby-Bauer disk diffusion method as published by the Clinical and Laboratory Standards Institute (CLSI, 2007). *Escherichia coli* and *Enterococcus* spp. isolates were inoculated into 5 mL of Brain Heart Infusion (BHI) broth (Difco, Fisher Scientific) and grown 4-6 hrs until optical density corresponded to a 0.5 McFarland Standard. The 0.5 McFarland Standard was made by the addition of 0.05 mL of 1% anhydrous barium chloride to 9.95 mL of 1% sulfuric acid, respectively ($\text{BaCl}_2 \cdot 2\text{H}_2\text{O}$) + (H_2SO_4). Following growth, a sterile cotton swab was used to swab the surface of Mueller-Hinton (MH) agar. A self-tamping BD Sensi-Disc™ Designer Dispenser System was used to introduce a panel of the following twelve antimicrobials. These antibiotics were selected as important representatives of different antibiotic classes, with abbreviations and disc

concentrations shown in brackets: streptomycin (S 10 μ g), cefotaxime (CTX 30 μ g), vancomycin (VA 30 μ g), ciprofloxacin (CIP 5 μ g), chloramphenicol (C 30 μ g), ceftriaxone (CRO 30 μ g), amoxicillin (AMC 30 μ g), doxycycline (D 30 μ g), ampicillin (AM 10 μ g), erythromycin (E 30 μ g), sulfisoxazole (G 0.25 mg) and sulfamethoxazole-trimethoprim (SXT 1.25 μ g) (Appendix, Table A1). Plates were incubated for 16-18 hrs at 35 \pm 2 $^{\circ}$ C for plates swabbed with presumptive *E. coli* and *Enterococcus* spp. isolates, and 18-24 hrs at 35 $^{\circ}$ C and 32 $^{\circ}$ C for *Aeromonas* spp. and *Yersinia* spp., respectively, after which zone diameters were interpreted to using published standards set by the National Committee for Clinical Laboratory Standards (CLSI, 2007) to categorize isolates as susceptible, intermediately resistant or resistant. For the purpose of analysis, intermediate sensitivities were considered resistant. A representative diagram of zone diameter interpretation is seen in Figure 2.1.

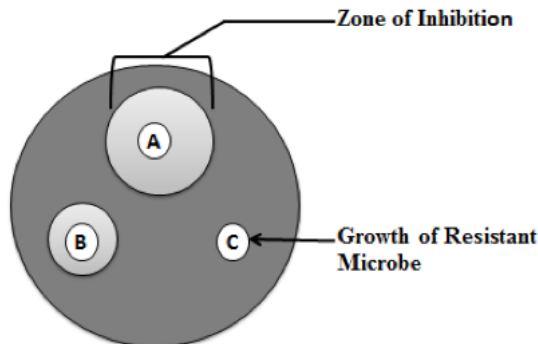

Figure 2.1. Simplified image depicting the differentiation of phenotypic antibiotic resistance. Numbered discs represent tested antibiotics, and a zone of inhibition (or clearing around the antibiotic disc) is indicative of bacterial susceptibility to the tested antibiotic. A lack of clearing around the disc is indicative of bacterial resistance.

2.3.1.5 Community-Level Physiological Profiling

The development of culture-based tools for the prediction and monitoring of natural attenuation in impacted waters requires insight into the relationship that exists between the microbial community, and hydrological and chemical parameters; such as redox and degradation processes (Roling *et al.*, 2001). While traditional microbiological cultivation techniques may be useful for different degrees of species identification, it can be argued that it is instead diversity in the functional, rather than taxonomic sense, which yields information regarding the role of the community in aquatic environments. Therefore, for studies aimed at investigating the composition, dynamics and stability of a microbial community would greatly benefit from an easily applied, reproducible and reliable method that yields information concerning functional diversity. For the purpose of this project, microbial functional diversity can be defined operationally as the types, numbers, activities and rates at which a given suite of carbon substrates are utilized by the microbial community in consideration.

One specific approach for the investigation of community function involves physiological profiling with Biolog© MicroPlate™ EcoPlate™ technology, developed for the study of environmentally derived samples. Originally described by Garland and Mills (1991), community level physiological profiling (CLPP) is recognized as a particularly valuable approach to characterize the metabolic function and overall stability of a microbial community over time, based on sole carbon source utilization patterns (CSUPs) (Weber and Legge, 2010). The generation of a CLPP entails the use of an EcoPlate™, which supplies different types of carbon sources and measures the capability, or the rate of a given microbial community to metabolize the substrates.

The EcoPlate™ is a microtitre plate with a total of 96 wells containing 31 carbon sources (in triplicate) and a blank well (water) acting as a control (Figure A3) (Weber and Legge, 2010; Weber *et al.*, 2007). Incorporated into each well of the plate is a redox sensitive tetrazolium violet dye, which undergoes a colour change to purple following respiratory metabolism of the substrate, and can be photometrically measured and analyzed to yield a CSUP. The colour change is indicative of metabolic activity and is an important indication of microbial growth in the community. More specifically, tetrazolium violet in its oxidized state is soluble in water and appears colourless or faintly yellow in solution (Garland and Mills, 1991). Upon contact with NADH (a by-product of carbon substrate oxidation), the tetrazolium violet is reduced to produce a purple formazan product, as shown in Figure 2.s. This formazan is insoluble in water, so the reduction can be considered essentially irreversible.

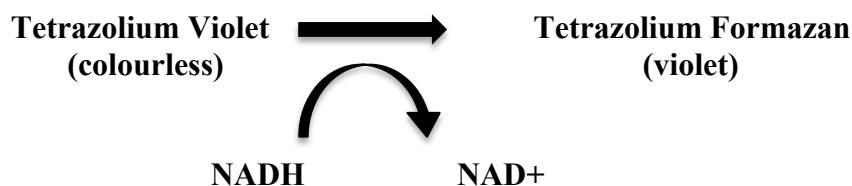

Figure 2.2 Reduction of tetrazolium violet dye incorporated into Biolog EcoPlates™.

The specific protocol employed in this project follows the procedure originally outlined by Weber and Legge (2010). Prior to inoculation of the Biolog© EcoPlate™, selected interstitial water samples were spectrophotometrically analyzed at a wavelength of 420nm in order to assess background carbon levels (Weber and Legge, 2010). Provided the optical density (OD) readings of the sample at 420nm were greater than 0.2, the sample was diluted one order of magnitude until the OD measurement was equal or less than 0.2. Following

spectrophotometry analysis, 150µL of each sample was inoculated into each well of the Biolog© EcoPlate™ with a multichannel pipette. Following inoculation into all assay wells, the microbial growth of the inoculated sample was measured at defined 24 hr intervals over a period of 120 using an xMark™ Microplate Absorbance Spectrophotometer (Bio-Rad Laboratories, CA) set to read at a defined wavelength of 590nm. Between readings, EcoPlates™ were incubated in the dark at $23 \pm 1^\circ\text{C}$. Provided the microbial community utilized the given substrate, the tetrazolium dye in the specific well underwent reduction to yield a purple colouration that best absorbs light at a wavelength of 590nm (Garland and Mills, 1991) (Figure 2.2).

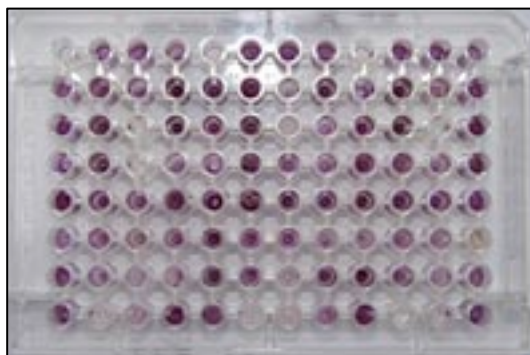

Figure 2.3 Representation of a Biolog EcoPlate™ inoculated with an environmental water sample following 96 hours of incubation. Purple colouration within a well indicates respiratory activity and utilization of respective carbon source. Blank wells are included in triplicate within the top row, in wells 1, 5 and 9.

CLPP has been reported to have considerable utility when used intelligently as a rapid, cost-effective method to determine the effects of various environmental factors on the biological profile of impacted water sites by following catabolic traits of the microbial

community (Weber *et al.*, 2008; Weber and Legge, 2010). It provides an opportunity to overcome the traditional drawbacks typically associated with time consuming culture-based methodologies, and offers an easily applied protocol capable of generating information concerning metabolic function and functional adaptations over space and time (Weber and Legge, 2010). There is little need for isolation, amplification, enrichment or processing of the given sample outside of any necessary dilution (Calbrix *et al.*, 2005). Conversely, Garland (1997) noticed the metabolic growth response, which involves both cooperative and competitive effects in EcoPlate™ wells, might be a (major) limitation of the CLPP approach. For example, due to the integrated nature of well response, it is indiscernible whether carbon utilization within a particular well is a result of metabolism by a single species or microbial cooperation. Furthermore, lack of metabolic response may signify competition within the well or inability of the microbial community present to utilize the provided substrates (Garland *et al.*, 1997). Considering that the complexity of well response permits for evaluation of microbial interactions, Garland *et al.* (1997) suggest that this limitation may also be viewed as an advantage of this unique approach.

Therefore, the real discriminatory power of the Biolog EcoPlate™ assay depends on the analysis of continuous data, with empirical evidence indicating that the profiles are effectively sensitive to shifts within the microbial community structure (Zak *et al.*, 1994).

Statistical Analysis

As originally published by Zak *et al.* (1994), Biolog EcoPlates™ can be used in a traditional ecological sense in order to develop functional diversity indices based on CSUPs. Owing to the large quantity of data points that can be generated with a single Biolog™ plate,

as well as the number of variables to be considered, multivariate analysis and other statistical procedures are commonly employed to examine diversity in communities.

The most commonly used diversity indices are simple transformations, but each diversity index can also be interpreted in its own right as a measure corresponding to some real phenomenon, with a different one for each diversity index. As indicated by Weber *et al.* (2008), the term "functional diversity" used by Zak *et al.* (1994) can be replaced with "substrate diversity" for this research, as it encompasses substrate utilization patterns. Calculated functional diversity patterns from carbon source metabolism are expressed in terms of metabolic richness, metabolic diversity, and average well colour development (AWCD). Unless otherwise stated, absorbance readings (590nm) at the 96 hr time point were identified as the metric for CLPP data analysis, following the rationale provided by Weber *et al.* (2008). Mean absorbance readings for each of the well types were calculated from the three replicate wells on each plate. These absorbance readings for the 31 carbon-source wells were then corrected for any colour development within the blank wells (water). Following the approach of Glimm *et al.* (1997), wells were standardized by dividing the average OD for each well by the average well colour development (AWCD) in the 31 carbon source-containing wells in order to reduce the effect of any inoculum density difference among all EcoPlates™ (Garland and Mills, 1991).

Shannon Diversity Index (H')

The Shannon Index (H' ; Shannon, 1948) has been the most commonly considered ecological metric employed to track and understand functional shifts in diversity within

microbial communities (Weber *et al.*, 2011). Primarily, it was proposed as a measure for computing species diversity, but its application for substrate utilization diversity has since been widely recognized (Weber and Legge, 2010; Weber *et al.*, 2008). H' is a measure of the number of substrates utilized (termed substrate richness) and the diversity of the extent of utilization of particular substrates (termed substrate evenness). The greatest/maximum H' value able to be generated for a Biolog EcoPlate™ is 3.434, which is equal to the natural logarithm for the total number of 31 available carbon substrates. This value will occur in the event that all carbon substrates within each of wells are metabolized equally. As a measure of diversity, values that range between 1 and 2 are considered low diversity, and values equal to or greater than 3 are considered indicative of high diversity (Weber and Legge, 2010). Using the carbon source utilization pattern generated from a single EcoPlate™, substrate diversity can be calculated as:

$$H'_{CLPP} = -\sum p_i \ln(p_i)$$

where:

- H'_{CLPP} is substrate diversity
- p_i is the ratio of the activity/absorbance of a particular substrate to the sum of activity of all substrates
- activity - chosen metric for analysis (absorbance value (590 nm) at 96 hr)

Substrate Richness

In addition to the Shannon Index, another parameter associated with substrate diversity that can be calculated using CSUP is substrate or metabolic richness (R). Substrate richness is considered a measure of the number of different carbon substrates utilized by a microbial community. Richness values can be calculated as the number of wells with a corrected absorbance (OD at 590nm) reading of 0.25 as threshold for positive response. (Weber and Legge, 2010).

$$R = \sum (\text{carbon sources} > 0.25 \text{ at } 590 \text{ nm})$$

Average Well Colour Development

One of the simplest means of obtaining an overall assessment of microbial community metabolic rate is average well colour development (AWCD) (Garland *et al.*, 1997). AWCD of Biolog EcoPlates™ is considered an important index for evaluating diversity of aquatic microbial communities. The values generated represent an overall estimate of the metabolic rate of the inoculated microbial community (Garland *et al.*, 1997). AWCD was calculated according to Garland and Mills (1991), where the sum of the corrected absorbance readings was divided by the total number of available carbon sources included in the EcoPlate™, as indicated below:

$$AWCD = \sum (C - \text{Ref}) / 31 \text{ Carbon Sources}$$

where:

- "C" is the average colour production within each of the wells containing a carbon substrate
- "Ref" is the average colour response of the blank or reference wells

2.3.2 Molecular-based Methods

Environmental DNA Extraction

Within 2 hours following delivery to the lab, 250 mL of each provided interstitial water sample were vacuum-filtered onto a 47 mm, 0.22 µm polycarbonate filter (Millipore™, Fisher Scientific, Whitby, ON, Canada), soaked in unbuffered PCR-grade Milli-Q (Millipore) water. With the aid of sterile forceps, each filter was then transferred into a provided PowerSoil™bead tube from the MoBio Powersoil DNA isolation kit (Mo Bio Laboratories Inc., CA). A No. 11 sterile blade (Feather, Fisher Scientific, Whitby, ON, Canada) on a sterile No.3 handled scalpel was used to lacerate the filter into small pieces, after which DNA extractions were carried out following the protocol outlined of the manufacturer.

DNA Extraction from Suspended Substrate Media

DNA was extracted from microbial biomass collected from 500 mL of sample water containing suspended substrata or biofilm scrapings ('BioBalls'- manufacturer unknown). Samples were subjected to sonication to remove biofilm material at 55kHz for 1 to 2 mins and resulting water suspension was concentrated by centrifugation using the 5702 Centrifuge (Eppendorf, Mississauga, ON, Canada) at 13,000 x g for 20 min at 4°C. Genomic DNA was extracted from interstitial water samples using the MoBio Powersoil DNA isolation kit,

following the manufacturer's protocol. Following genomic DNA extraction, purity and quantity of DNA extract was spectrophotometrically analyzed using the Biodrop Duo (Montreal Biotech Inc., Montreal, CA) for quantity (at 260 nm) and purity (A260/A280). All DNA was then stored at -20°C for downstream applications.

DNA Extraction from Control Organisms

Initially, microorganisms were individually grown in 5-10 mL of BHI broth at 35 ± 2°C for 16-18 hours. Following incubation, broth tubes were subjected to centrifugation at 13,000 x g for 10 min using a 5702 Centrifuge (Eppendorf, Mississauga, ON, Canada) in order to concentrate microbial growth/biomass. The supernatant was decanted, and the pellet was resuspended in the buffer provided in the bead tubes of the PowerSoil™ DNA isolation kit. The buffer containing the bacterial contents was then pipetted back into the bead tube, after which genomic DNA extractions were carried out according to the supplied manufacturer's protocol. The resulting DNA was then spectrophotometrically analyzed using the Biodrop Duo (Montreal Biotech Inc., Montreal, CA) for quantity (at 260 nm) and purity (A260/A280). All DNA was then stored at -20°C for downstream applications.

Molecular confirmation of Yersinia spp. and Aeromonas spp. isolates

Yersinia spp. isolates were identified and confirmed using the species-specific PCR primer sets, Y1 (5' AATACCGCATAACGTCTTCG 3') and Y2 (5' CTTCTTCTGCGAGTAACGTC 3'), and YER8 (5' GCGAGGAGGAAGGGTTAAGTG 3') and YER10 (5' GAAGGCACCAAGGCATCTCT 3') in order to differentiate between the two

Yersinia species, *Y. enterocolitica* and *Y. ruckeri*, respectively (Gibello *et al.*, 1999; Wannet *et al.*, 2001). Similarly, confirmation of *Aeromonas* spp. isolates was accomplished using genus-specific primers described by of the *gyrB* gene, which were originally designed/described by Yáñez *et al.* (2003). It has been previously reported that the *gyrB* gene is responsible for encoding the B-subunit of DNA gyrase and proves to be a suitable phylogenetic marker for bacterial systematics (Yáñez *et al.*, 2003). Therefore, confirmation of *Aeromonas* spp. isolates was accomplished using the genus-specific primer set *gyrB3F* (5' TCCGGCGGTCTGCACGGCGT3') and *gyr14R* (5' TTGTCCGGGTTGTACTCGTC 3') originally designed by Yáñez *et al.* (2003) for the detection of the *gyrB* gene; a gene proven to be responsible for encoding the B-subunit of DNA gyrase and having a mean synonymous substitution rate that is almost four times that of 16S rDNA (Yamamoto and Harayama, 1996), deeming it an excellent phylogenetic marker for bacterial systematics (Yáñez *et al.*, 2003). The three sets of PCR primers (Table 2.1) were used based on the published protocols originally described (Yáñez *et al.*, 2003; Gibello *et al.*, 1999; Wannet *et al.*, 2001) and were provided by Sigma-Aldrich Canada Ltd. (Oakville, ON, Canada). PCR amplification was performed using a BioRad™ I-cycler iQ PCR machine (Bio-Rad Laboratories; Mississauga, ON, Canada). Each 25µL PCR mastermix was prepared for *Y. enterocolitica*, *Y. ruckeri* and *Aeromonas* spp. and consisted of 5 X GoTaq Flexi Buffer (5 µL), 1.5 mM MgCl₂, 0.2 mM deoxynucleoside triphosphate mix, 1.0 U of GoTaq Flexi DNA Polymerase (Promega), various primer concentrations (Table 2.1) and 2.5 µL template DNA. Reaction conditions for *Y. enterocolitica* commenced with an initial denaturation step at 94°C for 5 min, after which products were subjected to 36 subsequent cycles consisting of heat denaturation at 94°C for 45 s, primer annealing at 62°C for 45 s, and extension at 72°C for 45 s. A final extension was performed at

72°C for 7 min in order to ensure complete synthesis of all strands. PCR conditions for *Y. ruckeri* entailed 25 cycles of denaturation at 92°C for 1 min, followed by annealing at 60°C for 1 min, and extension at 72°C for 1 min. A final extension step was performed for 5 min at 72°C. The conditions for *Aeromonas* spp. involved 35 cycles of amplification, including denaturation at 94°C for 30 s, annealing at 55°C for 30 s, and a final extension step completed at 72°C for 1 min. Following each PCR reaction, amplified products were held for short-term storage at 4°C, after which they were placed at -20°C for long-term storage.

In order to verify the success of the reaction, 10 µL of amplified PCR product was loaded into a 1.8% agarose gel in IX TAE buffer and subjected to running conditions of 100V for 60 min. Following electrophoresis, gels were stained using ethidium bromide (EB) and visualized using the BioRad™ GelDoc™ XR (Bio-Rad Laboratories) equipped with an amber filter. A positive reaction for *Y. enterocolitica*, *Y. ruckeri* and *Aeromonas* spp. involved the presence of a 330 bp, 575 bp, and 1100 bp band, respectively, and an absence of a band in the blank well which was run using 5 µL of Milli-Q water in place of DNA template.

Table 2.1. PCR primers, products, and reference strains for *Y. enterocolitica*, *Y. ruckeri* and *Aeromonas* spp. used for identification and confirmation

Strain	Primer	Sequence (5'–3')	Primer conc. for PCR mixture	Expected product size (bp)	Reference
<i>Y. enterocolitica</i>	Y1	AATACCGCATAACGTCTTCG	0.5µM (1.25µL)	330	Wannet <i>et al.</i> (2001)
	Y2	CTTCTTCTGCGAGTAACGTC			
<i>Y. ruckeri</i>	YER8	GCGAGGAGGAAGGGTTAAGTG	1.0µM (2.5µL)	575	Gibello <i>et al.</i> (1999)
	YER10	GAAGGCACCAAGGCATCTCT			
<i>Aeromonas</i> spp.	gyrB3F gyrB14R	TCCGCGGGTCTGCACGGCGT TTGTCCGGGTTGTACTCGTC	0.8µM (2µL)	1100	Yáñez <i>et al.</i> (2003)

2.3.2.1 Denaturing Gradient Gel Electrophoresis

The theoretical aspects of DGGE were originally described by Fisher and Lerman (1983), and later introduced by Muyzer (1999) to analyze the genetic diversity of complex microbial populations. It has been described to have a near 100% sensitivity for the resolving of different DNA fragments by as little as a single nucleotide. DGGE examines microbial diversity based on electrophoretic separation and mobility of same sized-PCR products in a polyacrylamide gel containing a linear gradient of denaturants, urea and formamide (Muyzer, 1999). Each PCR-amplified product presents with dissimilar base-pair (bp) sequences, and a unique denaturing threshold upon which separation occurs, termed a melting domain (T_m). Melting domains are dependent primarily on the fragment sequence (specifically guanine and cytosine content (G+C)), such that stretches of identical base pairings will have identical melting temperatures. Initially, products are separated according to molecular weight. As the fragment migrates through the gel, experiencing constantly applied voltage (70 V) and temperature (60°C), it is exposed to the concentration gradient where it will begin to partially undergo double-stranded dissociation and conformational change in the discrete melting domains. The greater the intrinsic stability of the fragment, the greater the denaturant condition must be in order to achieve bp dissociation. Conformational alteration from its native tertiary state to a "branched" form will impede/hinder the mobility of the fragment, resulting in eventual halting of the molecule as strand separation stretches over the entire length of the molecule (Nocker *et al.*, 2007). Sequence variants of particular fragments will therefore stop migrating at different positions in the denaturing gradient, resulting in a banding pattern representative of the microbial community in the sample (Muyzer, 1999). This banding pattern is indicative of a distinct response to the denaturing gradient, and is termed a "genetic

fingerprint". Myers *et al.* (1985) indicate that through use of DGGE, 50% of sequence variations can be detected in fragments up to 500bp. Considering that the migration distance of a fragment is largely a consequence of GC content, the attachment of a 40 bp GC-rich sequence (termed a GC clamp) to the 5' end of the forward primer during amplification has been shown to increase sensitivity of the reaction to nearly 100% (Myers *et al.*, 1985). The GC sequence addition acts as a high melting domain, stabilizing fragment migration such that complete dissociation into single strands is prevented. Following electrophoresis, gels undergo staining with SYBR Gold nucleic acid stain, imaged and digitally captured with a transilluminator where banding patterns are visualized. In principle, a single visualized band is theoretically illustrative of dominant bacterial species within the sampled community. However, due to the potential for co-migration of distinct sequences, the presence of single stranded DNA, or heteroduplex formations, bands are instead referred to as operational taxonomic units (OTUs) (Fromin *et al.*, 2002). Banding patterns can be normalized using computational software and reference patterns, permitting for identification of band positions through comparison.

DGGE is considered an effective genetic fingerprinting technique for monitoring spatial temporal variability in complex microbial communities from a variety of environmental settings, and provides a simple view of the dominant microbial species and biodiversity within a given sample (Muyzer and Smalla, 1998; Nubel *et al.*, 1996). In order to assess shifts in communities, interval sampling is generally required. DGGE represents a rapid, reproducible, and cost effective method that permits for large volumes of samples to be processed simultaneously, facilitating time series analysis and the assessment of sites with different environmental parameters/conditions. In this manner, the molecular-based technique of DGGE

and the culture-based approach of CLPP can be considered complementary, generating a structural fingerprint and functional fingerprint, respectively.

Polymerase Chain Reaction for DGGE

The V3 variable region of bacteria 16S rDNA from all interstitial water samples was amplified using the primers 357f (5'-CCTACGGGAGGCAGCAG-3') with a GC-clamp added to the 5' end (5'-CGCCCGCCGCGCCCCGCG-CCCGTCCCGCCGCCCCCGCCCG-3') and 518r (5'-ATTACCGCGGCTGCTGG-3'), as originally described by Ogino *et al.* (2001) (Sigma Aldrich; Oakville, ON, Canada). Each mastermix (final volume 50 μ L) contained 1 x Go-Taq™ Flexi (Promega) Green PCR Buffer, 1.5 μ M MgCl, 0.5 μ M of each primer, 200 μ M dNTP, 1.5 U Go-Taq™ Flexi (Promega) and 21.3 μ L of Milli-Q (Millipore) water. The template used for this PCR reaction was 5 μ L of extracted sample DNA (see section # for the DNA extraction protocol). In order to increase specificity of amplification and reduce formation of spurious byproducts, touchdown PCR was performed using a BioRad™ I-cycler iQ PCR machine (BioRad Laboratories, Mississauga, CA) according to the protocol described by Muyzer *et al.* (1993). An initial denaturation of 94°C for 5 min was followed by 20 cycles of 94°C, 65°C and 72°C for 1 min each. The annealing temperature of 65°C was decreased every 2 cycles by 1°C to a temperature of 56°C on the 20th cycle. This was followed by 10 additional cycles of 94°C, 55°C and 72°C for 1 min each. The final extension step consisted of 7 min at 72°C where after the final PCR product was held at 4°C until long-term storage at -20°C.

In order to verify the success of the reaction, aliquots (10 μ L) of PCR products were analyzed by conventional electrophoresis in 1.5% (w/v) agarose gel with IX TAE buffer (40

mM Tris- HCl pH 7.4, 20 mM sodium acetate, 1.0 mM (EDTA) and subjected to running conditions of 100 V for 60 min. Gels were stained with ethidium bromide (0.5 µg/mL in Milli-Q water) for 20 min and quantified by using a standard (DNA mass ladder 100 bp, Promega). Gels were imaged using a BioRad™ GelDoc™ XR (Bio-Rad Laboratories) with amber filter. A positive reaction involved the presence of a 233 bp band and an absence of a band in the blank which was run using 5 µL of Milli-Q water in place of the DNA template.

Running Conditions and Image Acquisition

DGGE was carried out following an adjusted procedure first described by Muyzer *et al.* (1993) and improved by Green *et al.* (2009). Samples containing approximately equal amounts of PCR amplicons (15 µL) were loaded into 8% (w/v) polyacrylamide gels in IX TAE buffer (40 mM Tris-HCl pH 7.4, 20 mM sodium acetate, 1.0mM Na₂-EDTA). All electrophoresis experiments were performed at 60°C using a denaturing gradient ranging from 40 to 65% (100% corresponded to 7M urea and 40% (v/v) formamide). Gels were electrophoresed for 17 hrs at 70 V (1190 V·h) using a CBS Scientific™ DGGE-2401 machine (CBS Scientific Inc., Del Mar, CA). Prepared DGGE ladder (7 µL) was loaded into the middle and/or outside lanes. The creation of the DGGE ladder is described in the following sub-section.

DGGE gels were then stained using a solution of IX SYBR Gold (diluted from a 10,000x stock (Invitrogen, Burlington, ON) made in IX TAE) for one to two hours. After this time, gels were transported to the BioRad™ GelDock™ XR (Bio-Rad Laboratories) where it was imaged using a BioRad™ SYBR Gold filter (Bio-Rad Laboratories). Quantity One® software was used to capture the image which could then be exported as an 8-bit tiff file, excluding overlays and saved at the scan resolution of 2879dpi at a size of 1360 x 1024.

Creation of DGGE Ladder

The standard DGGE ladder was created by individually PCR-amplifying DNA extracted from microbial species known to be ubiquitous in aquatic environments, including fish pathogens, as well as species resulting in bands which migrated distinctly and consistently through the gel. Control culture DNA was extracted according to the protocol previously outlined previously in this chapter (section 2.4). The ladder consisted of the following organisms (n= 14): *Bacillus subtilis* (ATCC® 11774), *Yersinia enterocolitica* (ATCC® 9610), *Salmonella enterica. ser typhimurium* (ATCC® 13311), *E. coli* (ATCC® 12292), *Arthrobacter aureescens* (ATCC® 13344), *Bacillus thuringiensis* (Ward's Science Plus), *Enterobacter cloacae* (ATCC® 35030), *Flavobacterium* spp. (ATCC® 51823), *Aeromonas salmonicida* (ATCC® 33658), *Aeromonas hydrophila* (ATCC® 21763), *Yersinia ruckeri* (ATCC® 29908), *Proteus mirabilis* (Ward's Science Plus), *Alcaligenes faecalis* (ATCC® 33950), and *Clostridium perfringens* (NCTC® 8237). All NCTC® and ATCC® strains were obtained from Inverness Medical Inc. (Ottawa, ON, Canada), while additional strains were obtained from Ward's Science Plus (Niagara Falls, ON, Canada).

Extracted DNA was subjected to individual PCR amplification using the V3-16S rDNA primer set 357F with GC clamp and 518R, according to running conditions described previous. Confirmation of PCR amplicon formation for each species was carried out by using aliquots (10 µL) of product analyzed by conventional electrophoresis in 1.5% (w/v) agarose gel with IX TAE buffer (40 mM Tris- HCl pH 7.4, 20 mM sodium acetate, 1.0 mM EDTA) and subjected to running conditions of 100 V for 60 min. Gels were stained with ethidium bromide (0.5 µg/mL in Milli-Q water) for 20 min and visualized by transillumination to confirm success of each reaction. After confirmation, post-PCR products (40µL) were combined in

equal ratios and diluted with a matched volume of Tris-HCL (pH 8; Sigma Aldrich; Oakville, ON, Canada) for a total volume yield of 960 μ L of stock DGGE ladder. This stock solution was used for all gels compared within a data set. Each time a batch of standard ladder stock solution was amplified, mixed and diluted, aliquots (5 μ L) were tested independently via electrophoresis on an agarose gel (1.5% (w/v)) to ascertain the confidence intervals (*i.e.*, fluctuations in band location or intensity due to variations in PCR amplification or mixing ratios). For the purpose of this project, a single ladder stock was used for all gels analyzed and reported herein.

Statistical Analysis

Measures of Genetic Diversity and Richness

Molecular-based fingerprinting techniques such as DGGE yield large data sets. Distinct banding patterns are considered a reflection of the genetic biodiversity of the community in consideration, where each individual discrete band refers to an OTU and is treated as a distinct bacterial population. This diversity can be both visualized as the banding pattern, but also quantified through biodiversity indices (Simpson *et al.*, 1999) where comparisons take into account the number, and relative intensity of each band. Statistical indices frequently used to interpret metabolic profiles (CLPP) can also be adapted for DGGE banding pattern analysis. As previously described, richness and diversity have been used to depict substrate utilization patterns in CLPP. Similarly, these parameters have application when conveying measures of genetic integrity and community composition in DGGE. Specifically, with regard to DGGE analysis, indices are expressed in terms of richness (*i.e.* the number of bands), evenness (*i.e.* variation in band intensities) and diversity (*i.e.* the pattern of richness and evenness within a

single given lane.) Considering these modified operational definitions, previously described diversity-determining equations can be employed. Specifically, the Shannon Index (H') can be easily calculated to describe possible variations in dominance among DGGE OTUs using the following equation:

$$H'_{DGGE} = -\sum p_i \ln(p_i)$$

where:

- H'_{DGGE} is genetic diversity
- p_i is the ratio of the relative intensity of a given OTU to the total number of OTUs in a given lane

Averaged Banding Patterns

In order to achieve comprehensive characterization of the structural dynamics of the communities, averaged banding patterns from DGGE banding profiles were created. Generation of these patterns took into consideration relative intensities of the OTUs as well as their respective migratory distances through the gel. According to their final resting position within the gel, bands were categorized into band movements groups. Since differential migration and sequence stability is dictated by G+C content due to the presence of a third hydrogen bond between G-C complementary base pairs, a higher denaturant concentration must be encountered before the melting of sequences rich in G+C content (Madigan and Martinko, 2006). Correspondingly, G+C rich OTUs are assigned a higher band movement

group, representing further migration distance in comparison to OTUs with less G+C content. This allows for visualization of changes in relative abundances of OTUs, while conserving information regarding their movement. It is important to consider that OTUs with similar G+C composition in ribosomal DNA are incorporated into the same band movement group, presenting a source of error in DGGE analysis pertaining to band migration. This may confound the interpretation of community structure, but does account for the fact that taxa with similar G+C content are phylogenetically similar (Wayne *et al.*, 1987).

Chapter 3: Results of Flow-Through Systems

3.1 *E. coli*, *Enterococcus* spp. and Heterotrophic Plate Count Enumerations

In the present study, traditional fecal indicator bacteria *E. coli* and *Enterococcus* spp., and total heterotrophic bacteria were isolated and enumerated from various locations within two land-based flow-through aquaculture systems (FTS-A and FTS-B) for comparative culture based characterization.

FTS-A: Northern Flow-Through Aquaculture System

Overall, the abundance of the fecal indicator bacteria *E. coli* and *Enterococcus* spp. were relatively low among all sampling events. Detectable loads that fell within the statistically relevant range were only observed on a single sampling event during August, and were only found within the treatment pond sampling location. Specifically, cultureable *E. coli* concentrations were approximately 10^2 CFU/100 mL and *Enterococcus* spp. concentrations were in the order of 10^4 CFU/100 mL. Detectable concentrations of these FIB were not found within any of the other sampled locations.

The frequency and spatial distribution of total heterotrophic bacteria cultivated for the annual sampling events is provided in Figure 3.1. As depicted in the graph, plate counts from sample locations obtained during warmer seasonal months (August 2013 and April 2014) were typically two orders of magnitude higher than counts collected from microbial communities during colder seasons (February and November 2013). Specifically, the average concentration for total heterotrophs within the FTS-A reached final concentrations of 10^9 and 10^8 CFU/mL for the August and April events, respectively. Comparatively, HPC counts for microbial communities sampled during winter events (February and November) each reached final

concentrations of 10^7 CFU/mL. Overall, some general trends were evident regarding the cultureable heterotrophic fraction across sampling locations within the rearing system. Generally, well water samples displayed the lowest concentration of heterotrophic bacteria among all sampling locations, regardless of season, with final concentrations of approximately 10^4 CFU/mL or lower. Specifically, well water samples obtained during winter months displayed the lowest concentration of cultureable heterotrophs, with February and November events displaying values of 10^3 CFU/mL. Comparatively, August and April well water samples were generally one order of magnitude higher, both displaying average total concentrations of 10^4 CFU/mL. Overall, an increasing trend in HPC values was observed from influent well samples to the treatment pond location, which continually demonstrated the highest concentrations of cultureable heterotrophic bacteria. The microbial community sampled during the August event displayed the highest fraction of cultureable bacteria, at 10^9 CFU/mL. As the rearing water reached the final polishing pond, HPC levels were generally maintained or minimally reduced by one order of magnitude.

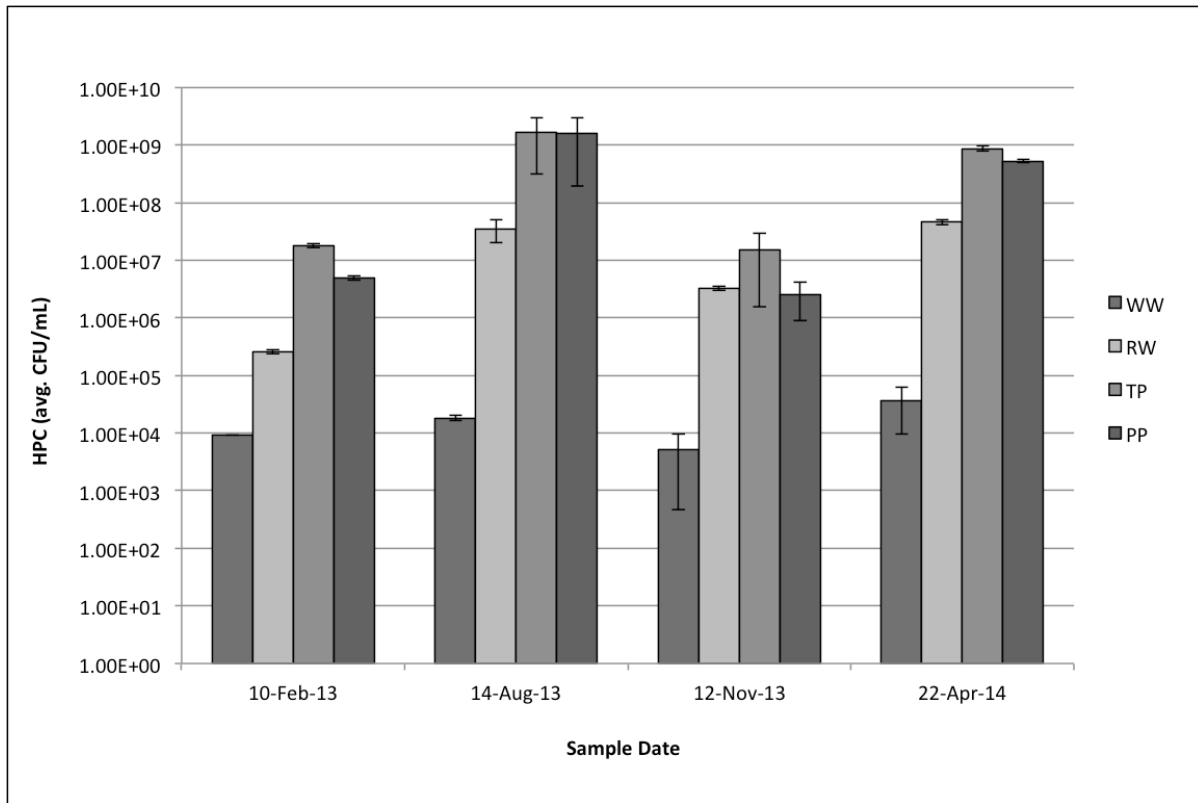

-well water (WW); raceway water (RW); treatment pond (TP) and polishing pond (PP)

Figure 3.1. Representation of total cultureable heterotrophic plate counts (HPC) as colony-forming units (CFUs) per mL over the sampling dates from February 2013 to April 2014 within the northern flow-through system (FTS).

FTS-B: Local Flow-Through Aquaculture System

The relative presence and abundance of indicator organisms *E. coli* and *Enterococcus* spp. throughout the FTS are depicted in Figure 3.2. Fecal indicator bacteria (FIB) loads were relatively low, in the range of 10^2 CFU/100 mL or lower over the course of the FTS for both initial and secondary sampling events. Generally, the highest concentrations of *E. coli* and *Enterococcus* spp. were most frequently detected in the pond water and discharge effluent samples during both sampling events, although concentrations did not exceed 10^2 CFU/ 100 mL. During the initial sampling event in June (2013) and secondary sampling event in May (2014), reduction in FIB levels did not occur to any extent throughout the course of the FTS. Reference levels for both *E. coli* and *Enterococcus* spp. within well water samples remained below detectable concentrations for both sampling events. Cultureable levels of FIB in pond water samples remained relatively consistent for both the initial and secondary sampling events, in the order of 10^2 CFU/100 mL. As the flow path of rearing water reached the early rear compartments, fecal concentrations displayed a log reduction to 10^1 CFU/100 mL. Comparatively, water samples obtained from the discharge effluent in the final stage of the system demonstrated a slight increase in fecal concentrations from both pond water and rearing water samples, with final concentrations persisting at 10^2 CFU/100 mL.

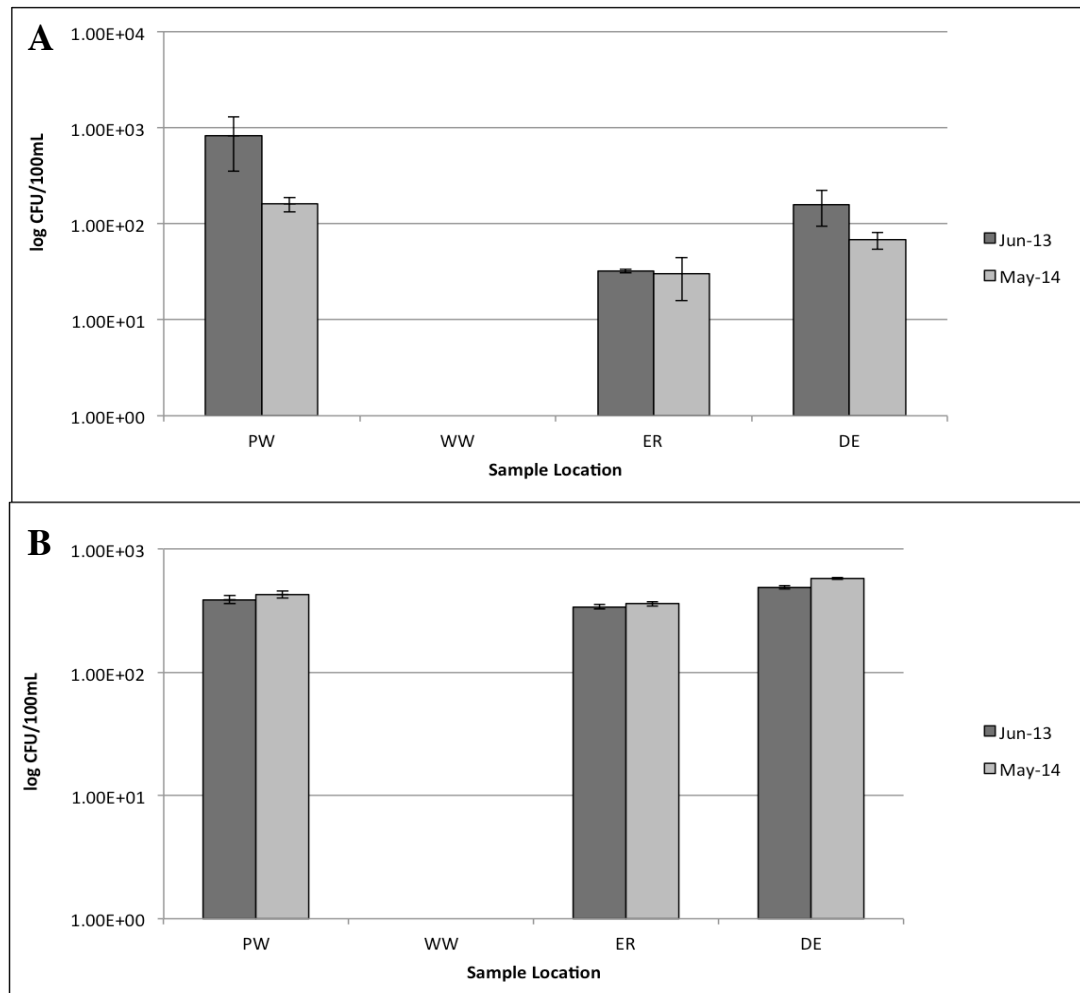

-pond water (PW); well water (WW); early rear water (ER) and discharge effluent (DE)

Figure 3.2. Mean values of (A) *E. coli* and (B) *Enterococcus* spp. as colony-forming units (CFUs) per 100 mL over two sampling dates in June (2013) and May (2014) within the local flow-through aquaculture system (FTS-B). Error bars represent standard deviation around mean values.

Comparatively, the average concentration for total heterotrophs within the FTS was higher than fecal indicator organism concentrations, reaching final concentrations of 10^8 CFU/100 mL for both the initial and secondary sampling events in June (2013) and May (2014), as illustrated in Figure 3.3. Little to no variation in HPC concentrations was observed among respective sampling locations between June and May events. There were some general

trends with respect to the topography of the flow path. Communities obtained from the on-site wells consistently demonstrated the lowest HPC concentrations, in the order of 10^3 CFU/100 mL or lower. Alternatively, influent pond water samples obtained during June and May were approximately three orders of magnitude higher, with values of 10^6 CFU/100 mL. As the rearing water reached the early rear compartment, HPC levels were either maintained or minimally decreased by one order of magnitude, respectively. In contrast, discharge effluent represented an increase in HPC concentrations to 10^8 , two orders of magnitude greater compared to early rear.

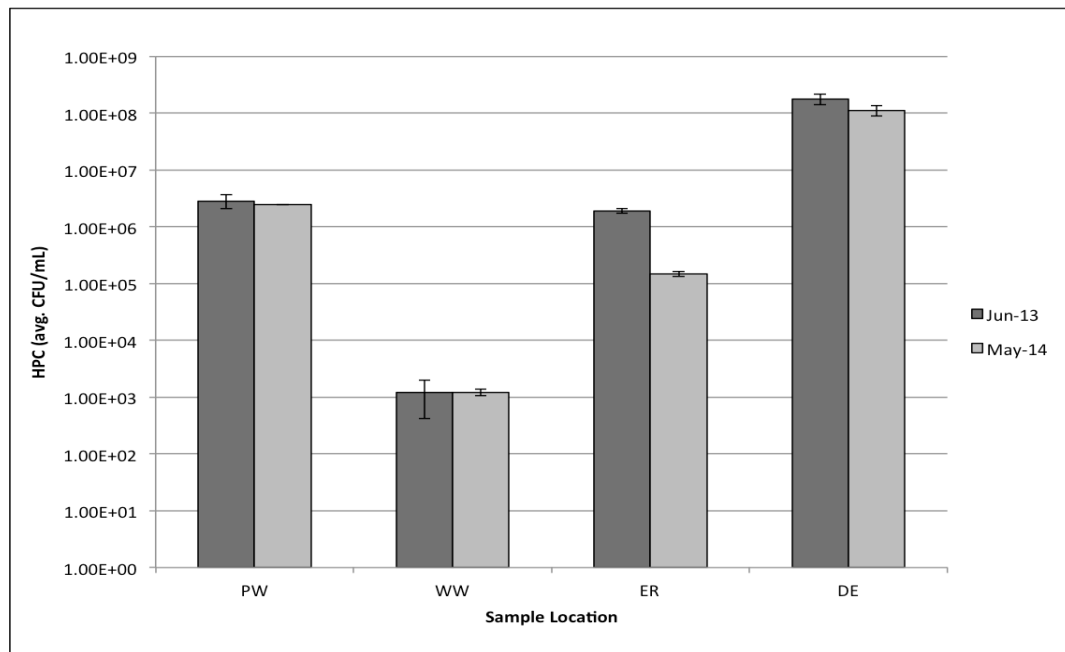

-pond water (PW); well water (WW); early rear water (ER) and discharge effluent (DE)

Figure 3.3. Representation of total cultureable heterotrophic plate counts (HPC) as colony-forming units (CFUs) per mL over the sampling dates in June (2013) and May (2014) within the local flow-through system (FTS-B). Error bars represent standard deviation around mean values.

3.2 Enumeration of Select Fish Pathogens in Flow-through Aquaculture Systems

With the use of selective and differential plating techniques, the enumeration of *Yersinia* spp. and *Aeromonas* spp. was carried out in order to phenotypically detect and characterize the respective pathogens from the impacted water sources flow-through systems in consideration. A collective summary of the number of bacterial species isolated from each FTS is depicted in Table 3.1.

Table 3.1. Summary of the total number of *Yersinia* spp., *Aeromonas* spp., and FIB isolates cultivated from the two field-scale aquaculture systems, (FTS-A and FTS-B) over the respective experimental monitoring periods.

Sampling Site	Sample Date	Total Number of Environmental Isolates			
		<i>Yersinia</i> spp.	<i>Aeromonas</i> spp.	<i>E. coli</i>	<i>Enterococcus</i> spp.
FTS-A (Northern FTS)	February 10 th , 2013	28	12	0	0
	August 16 th , 2013	30	10	0	3
	November 12 th , 2013	58	9	0	0
	April 25 th , 2014	15	12	0	5
	Total	197	47	0	8
FTS-B (Local FTS)	June 18 th , 2013	50	28	10	8
	May 13 th , 2014	50	30	6	2
	Total	100	58	16	10

FTS-A: Northern Flow-Through Aquaculture System

The total cultureable concentrations of the pathogens *Yersinia* spp. and *Aeromonas* spp. from four different sampling locations within FTS-A were enumerated during seasonal periods between February 2013 and April 2014. Annual total cultureable *Yersinia* spp. from sampling locations are illustrated in Figure 3.4A, while bacterial counts of *Aeromonas* spp. are depicted in Figure 3.4B. Results indicate general trends were evident with respect to both seasonality and spatial variation. Specifically, with respect to sampling location, the highest concentrations of total *Yersinia* spp. and *Aeromonas* spp. were generally observed for samples obtained from the treatment pond, with concentrations of approximately 10^9 CFU/100 mL and 10^4 CFU/100 mL, respectively. Overall, *Yersinia* spp. and *Aeromonas* spp. pathogen loads did not display a significant reduction from raceway water to the final polishing pond, such that final concentrations of 10^5 to 10^9 CFU/100 mL and 10^3 to 10^4 CFU/100 mL were detected in the polishing pond, respectively. In fact, during the sample event in April, *Yersinia* spp. loads in the polishing pond were increased by one order of magnitude compared to raceway and treatment pond concentrations. Among all sampling seasons, total cultureable *Yersinia* spp. values between the various sampling locations ranged between 10^5 to 10^9 CFU/100 mL while total cultureable *Aeromonas* spp. ranged between 10^2 to 10^4 CFU/100 mL. Comparatively, detectable concentrations of cultureable *Yersinia* spp. and *Aeromonas* spp. in well water samples were below the statistically relevant range among all seasonal events, indicating pathogen introduction to the system likely did not occur through influent well water.

Generally, with respect to seasonal variation, higher pathogen concentrations of *Yersinia* spp. and *Aeromonas* spp. were observed during the August and April events, approximately one to two orders of magnitude greater than concentrations observed during winter sampling events in February and November. Overall, *Yersinia* spp. was minimally

reduced throughout the on-site ponds by approximately one order of magnitude from the treatment pond to the final polishing pond, with the exception of the April sampling event. This pattern is similarly reflected with regard to *Aeromonas* spp. concentrations, whereby levels were generally reduced one order of magnitude from treatment pond to polishing pond.

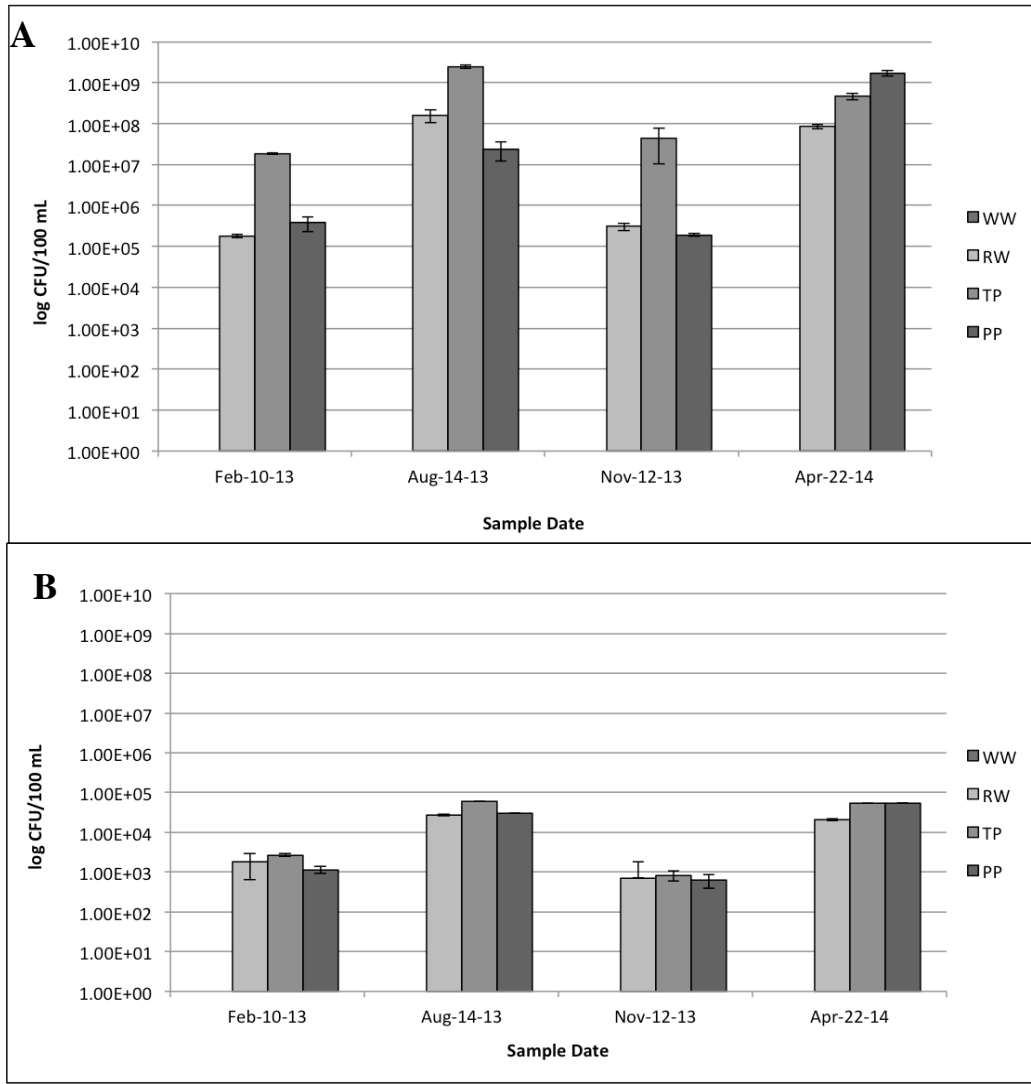

-well water (WW), raceway water (RW), treatment pond (TP) and polishing pond (PP)

Figure 3.4. Enumeration results of total cultureable *Yersinia* spp. (A) and *Aeromonas* spp. (B) as colony-forming units (CFUs) per 100 mL from respective sampling locations in a northern flow-through aquaculture system (FTS-A) monitored across four seasons.

FTS-B: Local Flow-Through Aquaculture System

Results for total cultureable *Yersinia* spp. are reported in Figure 3.5A and results for *Aeromonas* spp. are reported Figure 3.5B. In particular, detectable concentrations of cultureable *Yersinia* spp. and *Aeromonas* spp. were not observed within influent well water samples. In comparison, communities obtained from the on-site pond demonstrated concentrations of *Yersinia* spp. for both June (2013) and May (2014) samples, with log values of 10^8 CFU/100 mL for each event. Overall, *Yersinia* spp. loads were not reduced to any extent throughout the system, with discharge effluent concentrations approximately 10^8 CFU/100 mL. Comparatively, the average concentration for *Aeromonas* spp. in the FTS was highest within the pond water, reaching 10^5 CFU/100 mL. Values in the early rear samples indicate a one to two log reduction in *Aeromonas* spp. loads from pond water samples. Overall, discharge effluent loads were approximately two orders of magnitude lower than pond values, with final concentrations at 10^2 to 10^3 CFU/100 mL.

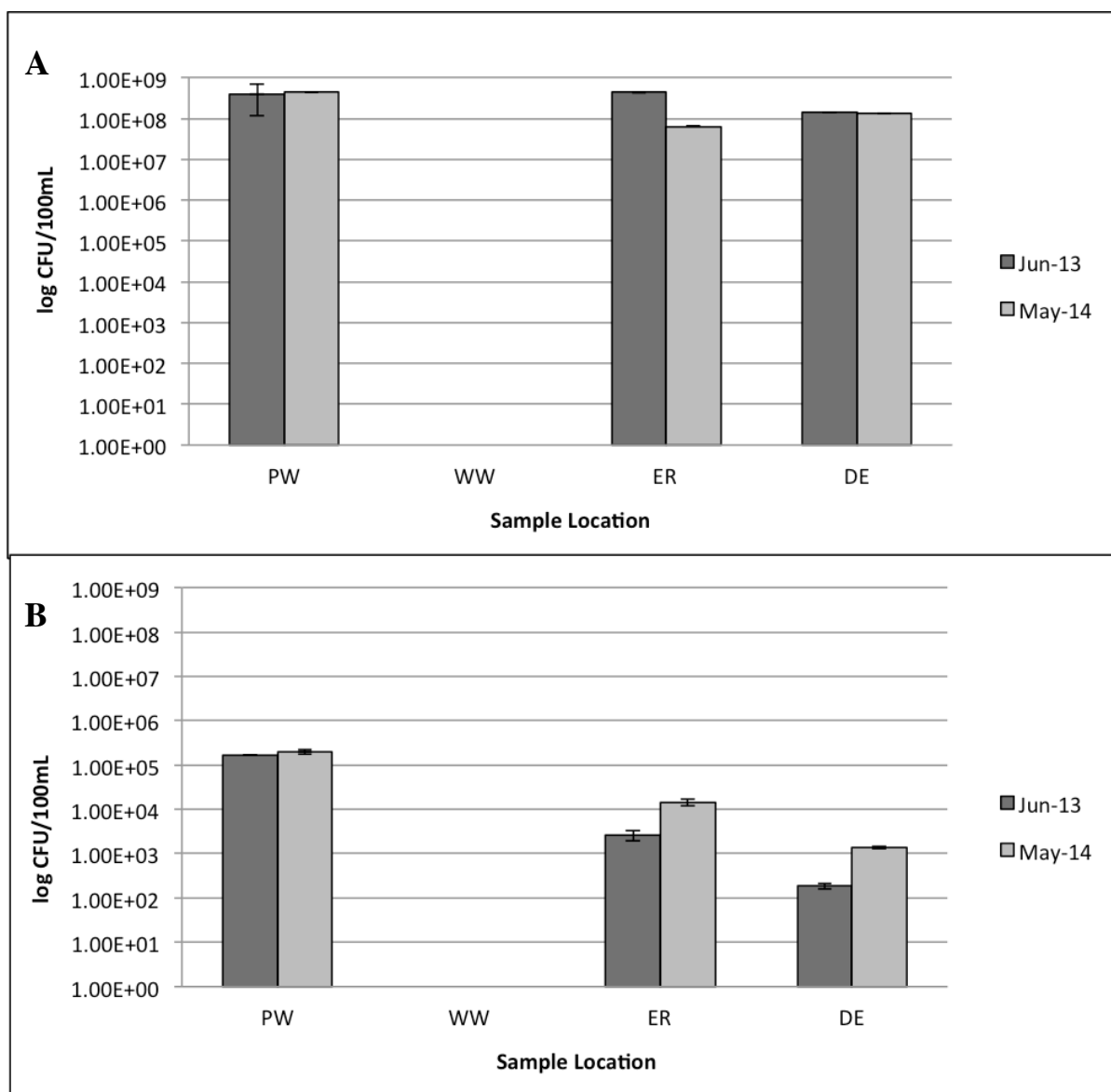

-pond water (WW); well water (WW); early rear water (ER) and discharge effluent (DE)

Figure 3.5. Enumeration results of total cultureable *Yersinia* spp. (A) and *Aeromonas* spp. (B) as colony-forming units (CFUs) per 100 mL from respective sampling locations in a local flow-through aquaculture system monitored across two summer sampling dates in June 2013 and May 2014 (FTS-B).

3.2.1 Qualitative PCR to Confirm and Characterize *Yersinia* spp. and *Aeromonas* spp.

FTS-A: Northern Flow-Through Aquaculture System

Genotypic confirmation using qualitative PCR was performed on a total of 197 presumptive *Yersinia* spp. isolates and 47 presumptive *Aeromonas* spp. isolates, collected from sampling locations within FTS-A during four seasonal sampling events between February 2013 and April 2014. Specifically, *Yersinia* spp. isolates were characterized using species-specific PCR in order to distinguish between *Y. ruckeri* and *Y. enterocolitica*, as genus-specific PCR primers for *Yersinia* spp. have not previously been developed. Table 3.2 summarizes these results. Among the total number of screened presumptive *Yersinia* spp. isolates (n=197), 30% (59/197) were genotypically confirmed as *Y. enterocolitica*, while only 2% (4/197) were characterized as *Y. ruckeri*. Similarly, genotypic confirmation of presumptive *Aeromonas* spp. isolates was performed (Table 3.2) using genus-specific PCR primers of the gene *gyrB*, which has previously been designed for confirmation of the genus *Aeromonas* (Yanez *et al.*, 2003). In total, 47 presumptive isolates were screened, with 63.8% (30/47) confirmed as *Aeromonas* spp.

Table 3.2. Molecular confirmation of presumptive *Aeromonas* spp. isolates and distribution of *Y. enterocolitica* and *Y. ruckeri* among screened isolates cultivated from FTS-A during seasonal sampling events.

Species	Total # of Isolates Screened	Confirmed +ve by PCR	% Confirmation
<i>Y. enterocolitica</i>	197	(59/197)	30.0%
<i>Y. ruckeri</i>	197	(4/197)	2.0%
<i>Aeromonas</i> spp.	47	(30/47)	63.8%

FTS-B: Local Flow-Through Aquaculture System

Genotypic confirmation using qualitative PCR was performed on a total of 100 presumptive *Yersinia* spp. isolates and 58 presumptive *Aeromonas* spp. isolates, collected from sampling locations within FTS during June (2013) and May (2014). Specifically, *Yersinia* spp. isolates were characterized using species-specific PCR in order to distinguish between *Y. ruckeri* and *Y. enterocolitica*, as genus-specific PCR primers for *Yersinia* spp. have not previously been developed. Table 3.3 summarizes these results. Among the total number of screened presumptive *Yersinia* spp. isolates (n=100), 31% (31/100) were genotypically confirmed as *Y. enterocolitica*, while only 11% (11/100) were characterized as *Y. ruckeri*. Similarly, genotypic confirmation of presumptive *Aeromonas* spp. isolates was performed (Table 3.3) using genus-specific PCR primers of the gene *gyrB*, which has previously been designed for confirmation of the genus *Aeromonas* (Yanez *et al.*, 2003). In total, 58 presumptive isolates were screened, with 58.6% (34/58) confirmed as *Aeromonas* spp.

Table 3.3. Molecular confirmation of presumptive *Aeromonas* spp. isolates and distribution of *Y. enterocolitica* and *Y. ruckeri* among screened isolates cultivated from FTS-B during seasonal sampling events.

Species	Total # of Isolates Screened	Confirmed +ve by PCR	% Confirmation
<i>Y. enterocolitica</i>	100	(31/100)	31.0%
<i>Y. ruckeri</i>	100	(11/100)	11.0%
<i>Aeromonas</i> spp.	58	(34/58)	58.6%

3.2.2 Frequency of Antibiotic Resistance among Waterborne *Yersinia* spp., and *Aeromonas* spp. isolated from a Local Flow-Through System (FTS-B)

Antibiotic resistance (ABR) profiling results were generated for all *Yersinia* spp. and *Aeromonas* spp. isolates cultivated from the flow-through aquaculture system (FTS-B) using the Kirby Bauer disk diffusion method. It should be noted that the difference in the number of isolates (n) screened for antibiotic resistance during the two sampling events resulted from a limitation in the number of cultureable isolates enumerated at the time (due to difficult growth requirements/conditions). Furthermore, it is important to note that ABR was only conducted for FTS-B due to time-constraints and that ABR was conducted on all presumptive *Yersinia* spp. and *Aeromonas* spp. isolates, as molecular confirmation was not carried out until after the antibiotic testing.

Observations were made regarding the frequency of multiple drug resistances (MDR), defined in this study as phenotypic resistance to three or more of the tested antibiotics. Table 3.2 summarizes the MDR rates with respect to pathogen progression throughout the system, and across the two summer events in which sampling was conducted. Among the total 100 *Yersinia* spp. isolates cultivated from FTS-B, 63.0% (63/100) exhibited MDR, while 65.5 % (38/58) of the *Aeromonas* spp. isolates were considered MDR. A comparison of the total MDR rates for the two sampling events in May (2013) and June (2014) reveals that MDR rates for *Yersinia* spp. were not observed to significantly increase among sampled locations. Alternatively, total MDR for *Aeromonas* spp. isolates demonstrated a 16.2% increase from the initial sampling event in June to the secondary event in May. In general, as FTS-B *Yersinia* spp. progressed throughout the system, MDR rates were observed to increase. For example, June *Yersinia* spp. obtained from the discharge effluent exhibited a 25.5% higher MDR

frequency compared to isolates obtained from the on-site pond. Comparatively, May discharge effluent isolates demonstrated a 40.8% higher MDR frequency than those extracted from the pond water. This trend was similarly reflected for MDR frequency in *Aeromonas* spp. isolates, whereby June and May discharge effluent isolates were 50.0% and 46.6% higher than pond MDR rates, respectively. Nonetheless, it should be noted that the relatively small sample sizes of isolates obtained from various sampling locations (e.g. N=5) may bias these trends.

Table 3.2. Frequency (%) of multiple drug resistance (MDR) in isolated pathogens *Yersinia* spp. and *Aeromonas* spp. from various locations within the local flow-through aquaculture system over two summer sampling events in June 2013 and May 2014.

MDR frequency (No. of MDR isolates/total isolates) for each location sampled						
	Sampling Event	Pond Water	Well Water	Early Rear	Discharge Effluent	Total % MDR
<i>Yersinia</i> spp.	June 2013	40% (2/5)	ND ^a	62.5% (10/16)	65.5% (19/29)	62.0% (31/50)
	May 2014	33.3% (3/9)	ND ^a	64.2% (9/14)	74.1% (20/27)	64.0% (32/50)
	Total:					63.0% (63/100)
<i>Aeromonas</i> spp.	June 2013	33.3% (3/9)	ND ^a	66.6% (8/12)	83.3% (5/6)	57.1% (16/28)
	May 2014	40.0% (2/5)	ND ^a	70.0% (7/10)	86.6% (13/15)	73.3% (22/30)
	Total:					65.5% (38/58)

^aMDR, Isolates displaying antibiotic resistance to three or more tested antibiotics (≥ 3)

ND^a, Isolates not detected in statistically relevant levels at location

Overall Resistance Patterns

Overall resistance patterns were generated for all isolates based on the specific antibiotic tested by combining ABR profiles for each of the FTS-B *Yersinia* spp. and *Aeromonas* spp. isolates across all locations sampled during the May (2013) and June (2014) events. As illustrated in Figure 3.6A, the prevalence of antibiotic resistance (%) among *Yersinia* spp. isolates varied among antibiotic classes tested. On average, 100% of *Yersinia* spp. isolates from both the June 2013 and May 2014 sampling events displayed resistance to the antibiotics AMC, E, and OTC, which belong to the β -lactam, macrolide, and tetracycline classes, respectively. Initial June 2013 resistance occurrence indicated high levels of resistance demonstrated for VA (94%), CRO (88%), C (80%), AM (78%) and CTX (62%). Comparatively, the *Yersinia* spp. isolates were found to be most susceptible to SXT, with 90% susceptibility, followed by 84% susceptibility to CIP, as demonstrated during the initial sampling event. Notably, there were no instances in which total antibiotic efficacy were observed during either sampling event. Resistance occurrence levels for the secondary sampling event (May 2014) were comparable to resistance levels from the initial sampling event, with high resistance again demonstrated for C (94%), VA (92%), CRO (90%), AM (84%), and CTX (72%) (Figure 3.6A).

Correspondingly, ABR profiles for *Aeromonas* spp. isolates revealed 100% (58/58) of isolates from both June and May events were resistant to the antibiotics E, OTC, and AM (Figure 3.6B). Isolates obtained during the June (2013) event indicated high levels of resistance exhibited for D (78%), SXT (75%), AMC (71%), VA (75%), and S (64%). Resistance levels for *Aeromonas* spp. obtained the following year during the May (2014) event were comparable with May (2013), with high percent resistance again demonstrated for AMC,

VA, D, SXT, and S, at 86%, 79%, 79%, 76% and 66%, respectively. In general, *Aeromonas* isolates exhibited complete susceptibility to the effects of CIP, with 0% resistance observed during both June and May. Additionally, results demonstrate the effectiveness of CTX and CRO, with 93% and 90% percent susceptibility against *Aeromonas* strains isolated from the flow-through system, respectively.

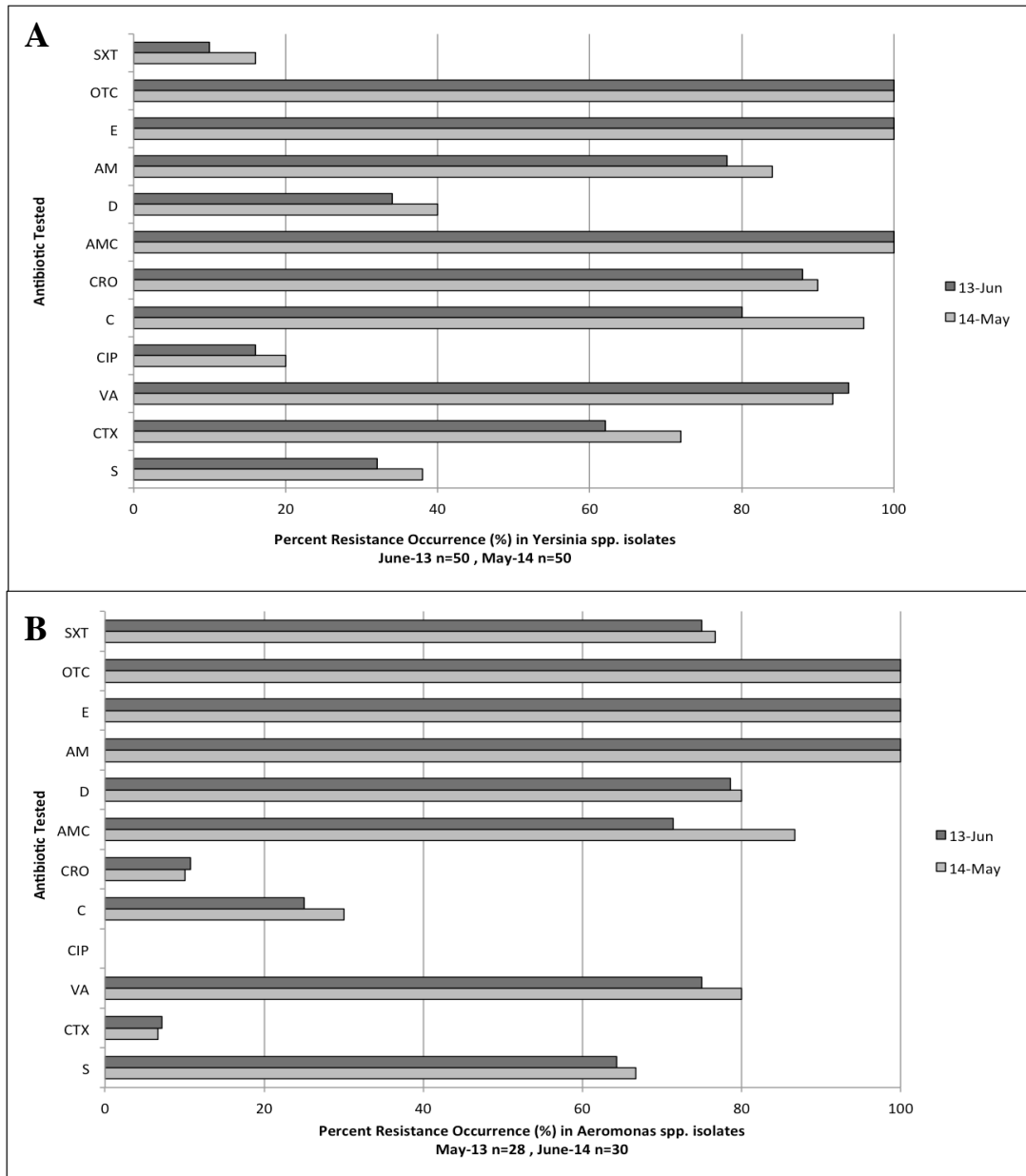

Streptomycin (S); Cefotaxime (CTX); Vancomycin (VA); Ciprofloxacin (CIP); Chloramphenicol (C); Ceftriaxone (CRO); Amoxicillin (AMC); Doxycycline (D); Ampicillin (AM); Erythromycin (E); Oxytetracycline (OTC) and Sulfamethoxazole-trimethoprim (SXT).

Figure 3.6. Percentage of resistance demonstrated in FTS-B *Yersinia* spp. (A) and *Aeromonas* spp. (B) isolates to a range of antibiotics over two sampling events on June 18th, 2013 and May 13th, 2014.

3.3 Community-Level Physiological Profiling of Communities

In addition to tracking the overall cultureable fraction of the community using a traditional culture-based approach, including heterotrophic bacteria and pathogens of interest, Biolog EcoPlates™ were utilized to characterize the microbial communities within different spatial regions in two flow-through aquaculture systems, FTS-A and FTS-B, based on sole carbon source utilization patterns.

FTS-A: Northern Flow-Through Aquaculture System

Functional profiling results indicate distinct trends with respect to the metabolic rates of the FTS microbial communities depending on the sampling season and location within the system. The average well colour development (AWCD) of inoculated Biolog© EcoPlates™ was calculated for each sample date and location and is presented in Figure 3.7A. Results indicate that across all sampling locations, the treatment pond microbial communities demonstrated the highest rates of metabolism compared to communities from the other system locations. Conversely, communities obtained from influent well water samples appeared to exhibit the lowest rates of carbon source metabolism, regardless of season. While AWCD results generally indicated an increasing trend in microbial community carbon metabolism throughout the stages of the system until peak values in the treatment pond, a reduction in community metabolic capability was observed in the final polishing pond, regardless of season.

AWCD values were also considered with regard to seasonality, as sampling events occurred during different seasonal periods. Microbial communities extracted during warmer seasonal months (August 2013 and April 2014) consistently exhibited higher rates of carbon source metabolism than communities sampled during colder months (February and November

2013). This pattern was similarly reflected with regard to the metabolic diversity of the microbial community, calculated according to the Shannon Index (H') and is depicted in Figure 3.7B. Microbial communities sampled during the colder climate events in February and November demonstrated the lowest functional diversity, with measured H' values just over 3.2 for both events, while higher diversity values were exhibited by communities obtained during the warmer seasonal events (August and April). Comparable to AWCD trends, communities within the treatment pond demonstrated the highest functional diversity, regardless of season. Interestingly, while a marginal reduction in substrate diversity was observed in polishing pond communities compared to those from the treatment pond, values remained comparably higher than both well water and raceway samples. Overall, minimal variation between sample locations was observed in terms of metabolic richness, or the or the total number of carbon sources metabolized resulting in an absorbance reading at 590_{nm} equal to 0.25 or greater, across all seasonal sampling events (Figure 3.7C). Following 96 hrs of incubation, all treatment and polishing pond communities reached maximum potential by utilizing all 31 carbon sources supplied in the EcoPlateTM.

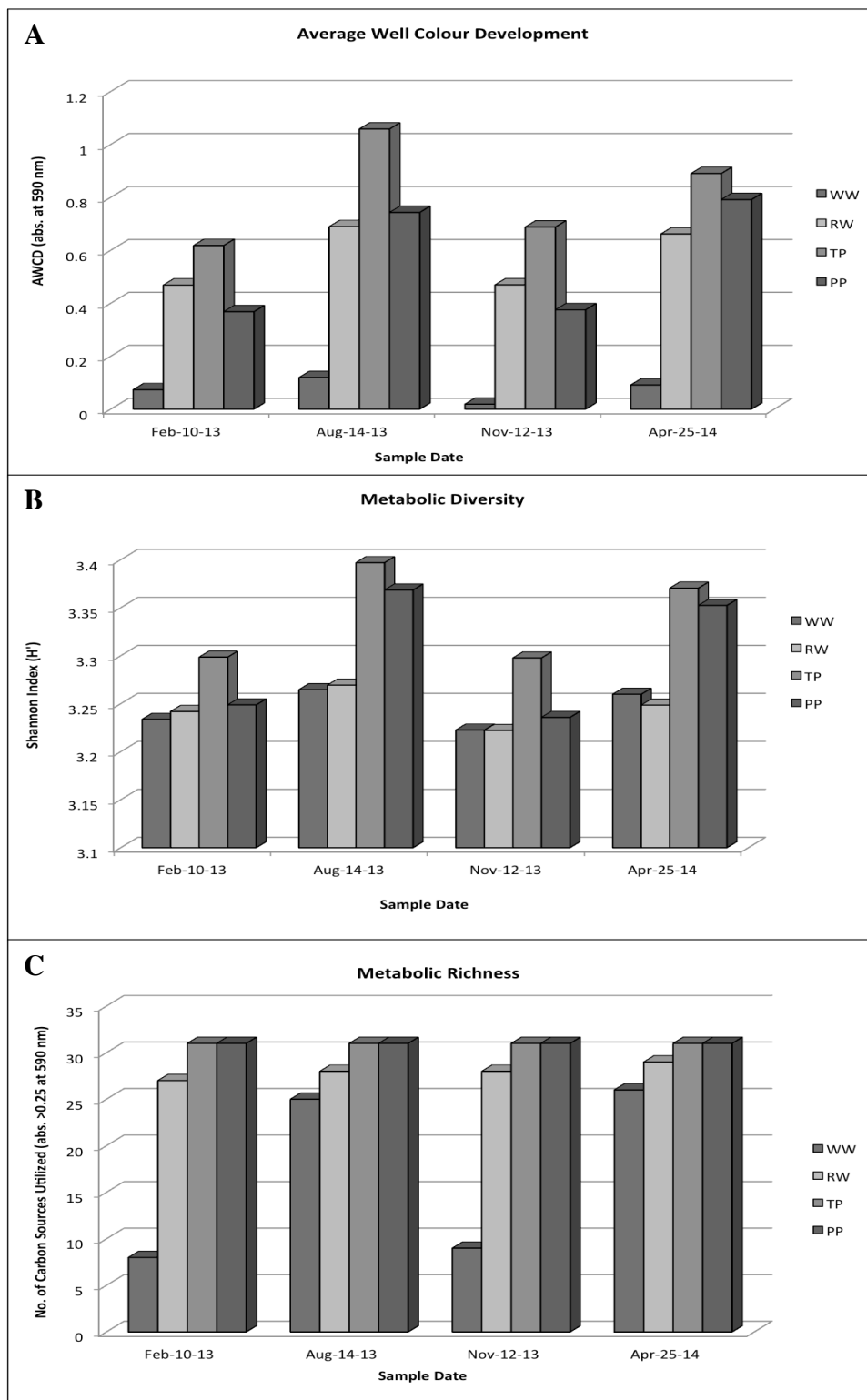
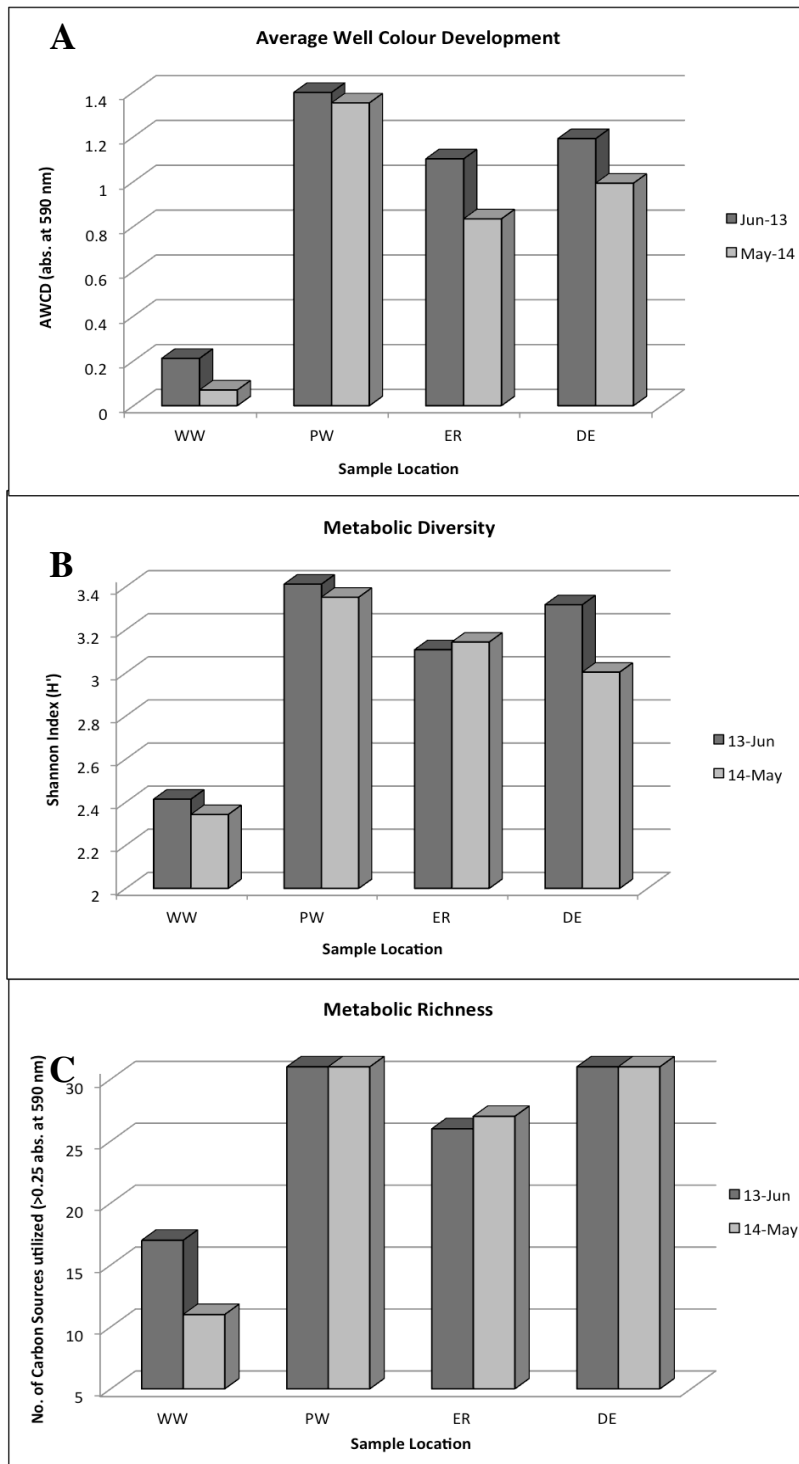

Figure 3.7. Community-level physiological profiles (CLPP) of microbial communities from the FTS-A based on (A) average well colour development, (B) metabolic diversity and (C) metabolic richness following a 96 hr incubation period.

FTS-B: Flow Through-System B

AWCD trends indicate that across all stages of the FTS, the June (2013) microbial community more readily metabolized the available carbon substrates than the May (2014) community (Figure 3.8A). Overall, some general trends were apparent that need mention. Among all locations sampled within the FTS, microbial communities extracted from the on-site pond consistently exhibited the highest metabolic rates, with OD₅₉₀ readings of approximately 1.39 and 1.35 for June and May events, respectively. In comparison, well water samples demonstrated significantly lower AWCD values of 0.2 or lower. A reduction in metabolic rates from pond water to early rear was observed for both June and May communities, followed by a recovery in functionality in the discharge effluent. Metabolic diversity profiles indicate relatively high levels of diversity for both June and May communities (Figure 3.8B), with H' values for pond, early rear, and discharge effluent greater than or equal to 3.0. Similar to AWCD trends, well water communities exhibited the lowest functional diversity, with respective H' values of 2.4 or lower for June and May events. Generally, early rear communities exhibited reduced functional diversity compared to pond communities, but only the June community displayed a recovery in functionality in discharge effluent while the May community experienced further reductions in diversity. In terms of metabolic richness, pond water and discharge effluent communities sampled during June and May displayed the potential to utilize all 31 carbon sources following 96 hrs of incubation (Figure 3.8C). Conversely, early rear communities demonstrated utilization of 26 and 27 carbon sources, while well water communities utilized only 17 and 10, respectively.



-PW-pond water, WW-well water, ER-early rear water, DE-discharge effluent

Figure 3.8. Community-level physiological profiles (CLPP) of microbial communities from the FTS-B based on (A) average well colour development, (B) metabolic diversity and (C) metabolic richness following a 96 hr incubation period.

3.4 Structural Fingerprinting of Microbial Communities through DGGE

DGGE fingerprinting was completed for all samples obtained from FTS-A and FTS-B, resulting in a total n=16 and n=8 samples, respectively.

FTS-A: Northern Flow Through Aquaculture System

Results of DGGE analysis indicate observed genetic diversity was generally highest within the treatment pond and polishing pond location of the FTS, while the lowest species diversity was apparent within well water communities (Figure 3.9A). Peaks in genetic diversity within the treatment pond were observed for the August and April sampling events. Interestingly, genetic diversity appears to have been maintained for the February and November events, with minimal variation in H' values observed across the sampling locations. Conversely, sampling events during warmer months (August and April) display a generally increasing trend in genetic diversity from well water to the treatment pond, followed by a loss of diversity in the polishing pond. This pattern was again reflected with regards to genetic richness (Figure 4.9B), whereby microbial communities within the treatment and polishing ponds displayed the highest instances of species richness. Notably, as demonstrated with regard to species diversity, the polishing pond community sampled during April demonstrated a marked increase in species richness compared to the other sampled locations, with 15 OTUs. Overall, it should be considered that seasonal trends regarding species diversity and richness may be somewhat inconclusive, due to variances in these measured parameters throughout the FTS on a per season basis.

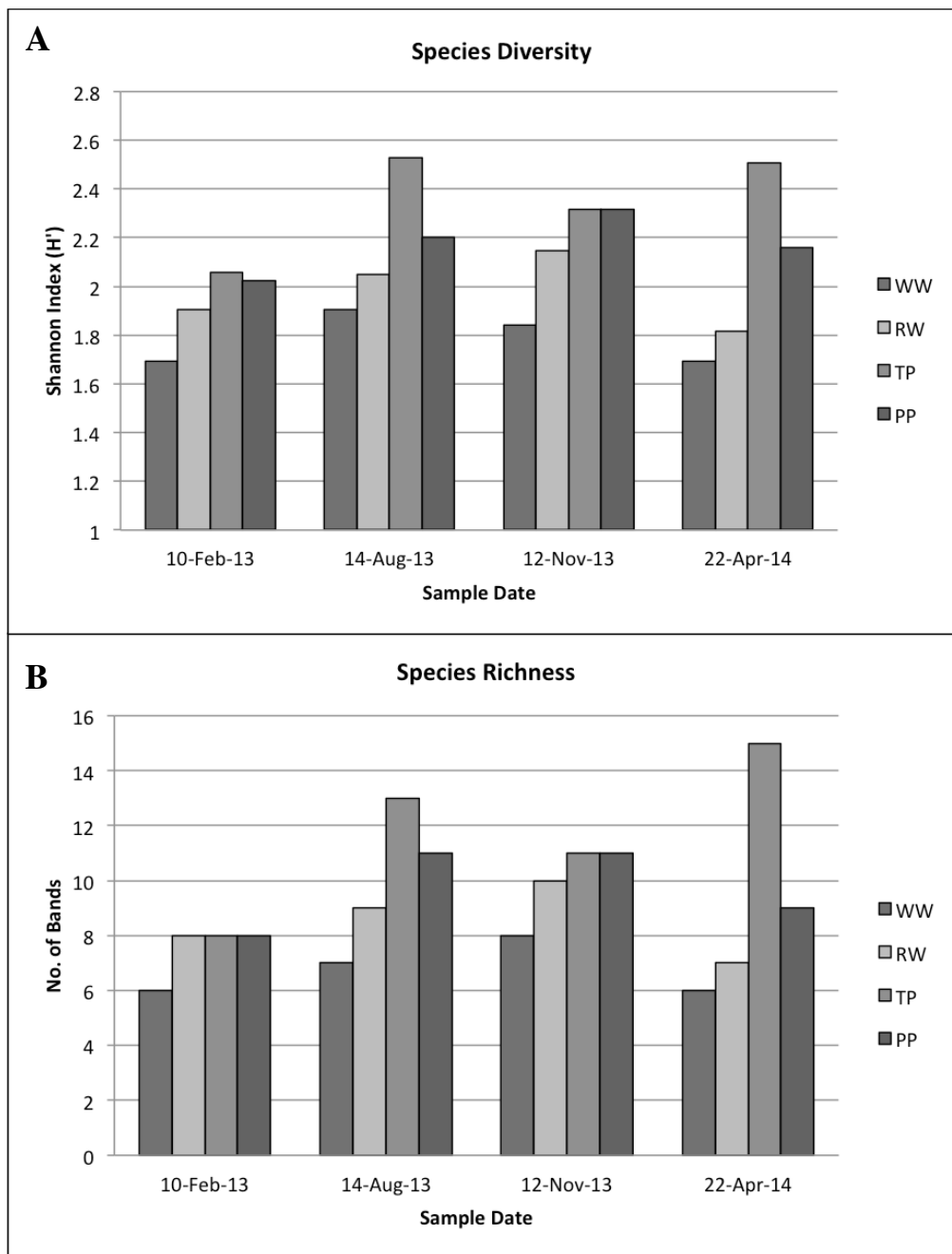

-WW-well water, RW-raceway water, TP- treatment pond, PP-polishing pond

Figure 3.9. DGGE-based community analysis of FTS-A samples obtained according to sampling location within the system and date, including (A) species diversity calculated using the Shannon Index (H') and (B) species richness as interpreted by number of bands within each sample.

In an effort to further characterize the structural dynamics of the microbial communities extracted from FTS-A, average banding patterns were generated based on the relative intensities of the bands and their respective migratory distances through the DGGE gel. Bands were categorized into 'band movement groups' (x-axis) according to final migratory distance and plotted against relative band intensity (y-axis). This graphical illustration serves as an indication of the G+C content of the OTUs, such that G+C rich groups are assigned to a higher band movement group than OTUs with low G+C content. Sequence stability and melting point is dictated by proportion of G+C content due to the three hydrogen bonds present between G-C pairs compared to the two hydrogen bonds between complementary A-T base pairs. Correspondingly, OTUs with a high G+C content were assigned to a higher band movement group, signifying further movement through the gel than G+C poor OTUs.

Changes in the abundances of detected OTUs throughout all sampling seasons (February-April) are illustrated in Figure 3.10, and is based on the averaged banding profiles generated for microbial communities within the various locations of the FTS. The well water microbial community obtained during the February sampling event appeared to contain a distinct dominating peak, indicating moderately low G+C content. Well water communities sampled during subsequent months demonstrate a more proportional distribution across band movement groups. Notably, August and November well water communities display a decrease in OTU diversity based on G+C content, whereby G+C poor peaks emerge. Overall, the well water communities indicate a generally increasing trend towards higher G+C content as the seasonal periods progress. Comparatively, the genetic structure of the raceway community in February was contained within two peaks of moderately low G+C content, followed by a shift

in genetic structure in August and November, such that OTUs were more evenly distributed. The final sampling event in the spring season (April) indicated a convergence of OTUs, represented by a single peak accounting for 100% of the total community. Alternatively, the genetic structure of the treatment pond remained fairly consistent throughout all seasons, resulting in a number of peaks that contributed relatively equal proportions to the community in the sampled location. Low G+C OTUs dominated the polishing pond location during all sampling seasons, vaguely resembling the structure and distribution observed for the well water communities.

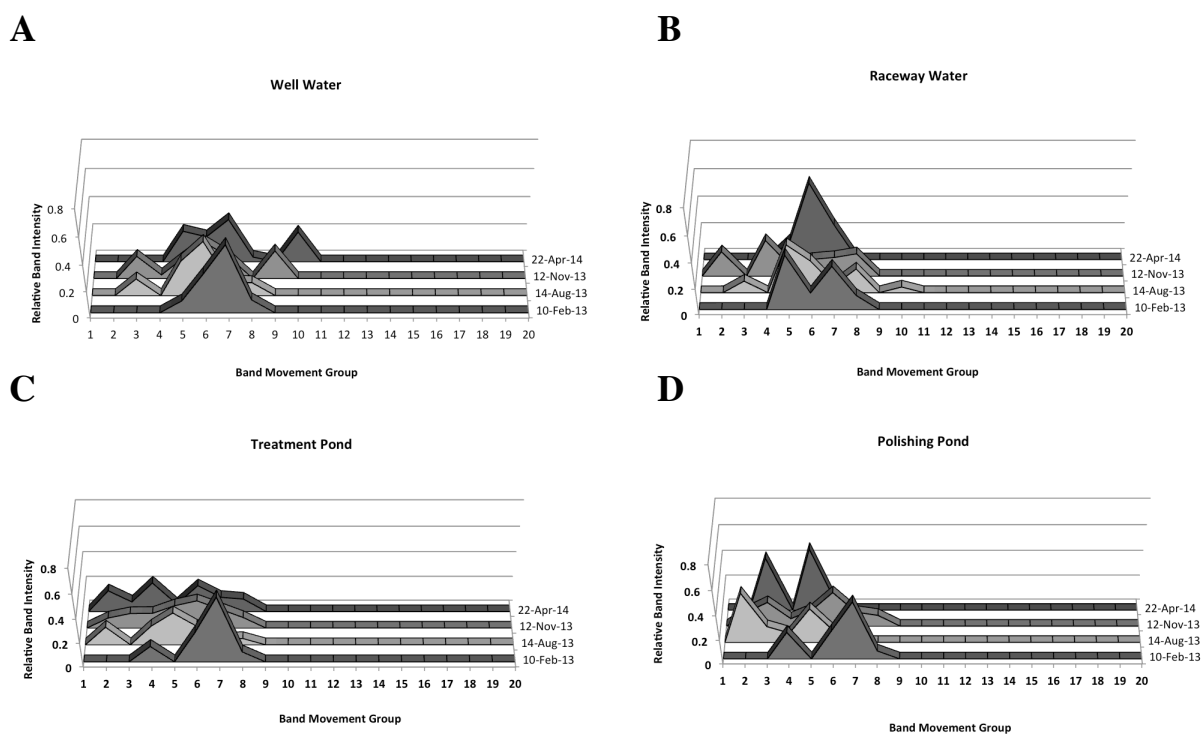

Figure 3.10. DGGE-based averaged banding patterns generated for sampling locations of the FTS-A and seasonal sampling dates including (A) well water, (B) raceway water, (C) treatment pond and (D) polishing pond.

FTS-B: Local Flow Through Aquaculture System

DGGE fingerprinting results for FTS-B are depicted in Figure 3.11. Across the different sampled locations of the FTS, the lowest species diversity was generally observed in the well water communities, with calculated H values of approximately 1.25 and 1.75 for June and May events, respectively (Figure 3.11A). In comparison, the pond and discharge effluent communities demonstrated the greatest compositional diversity. An apparent loss of diversity was observed in the communities within the early rearing location, followed by recovery within the discharge effluent. This general trend was again reflected in the structural richness of the community across the two sampling events (Figure 3.11B). Species richness measured in the pond and discharge effluent communities was consistently higher compared to the other sampled locations. For instance, 10 and 12 OTUs were observed for the discharge effluent communities in June and May, while 7 and 11 OTUs were observed in the pond water communities, respectively.

Based on the average banding patterns illustrated in Figure 3.12, the well water and early rearing communities sampled during June (2013) are dominated by two distinct peaks between the 4th and 9th band movement groups. The OTUs of the well water community were contained within the 4th and 8th movement groups, with peaks contributing 30% and 70% to the overall community composition. The communities extracted from the pond and discharge effluent locations demonstrated more expansive profiles, with OTUs of both moderate and high G+C content. In comparison, microbial communities sampled from all system locations during the May (2014) event demonstrated more evenly distributed profiles than those from June (2013), with an increase in OTUs of higher G+C content evident among all samples. The

discharge effluent communities sampled in May were dominated by moderate G+C OTUs, while the pond water communities were composed primarily of low G+C OTUs.

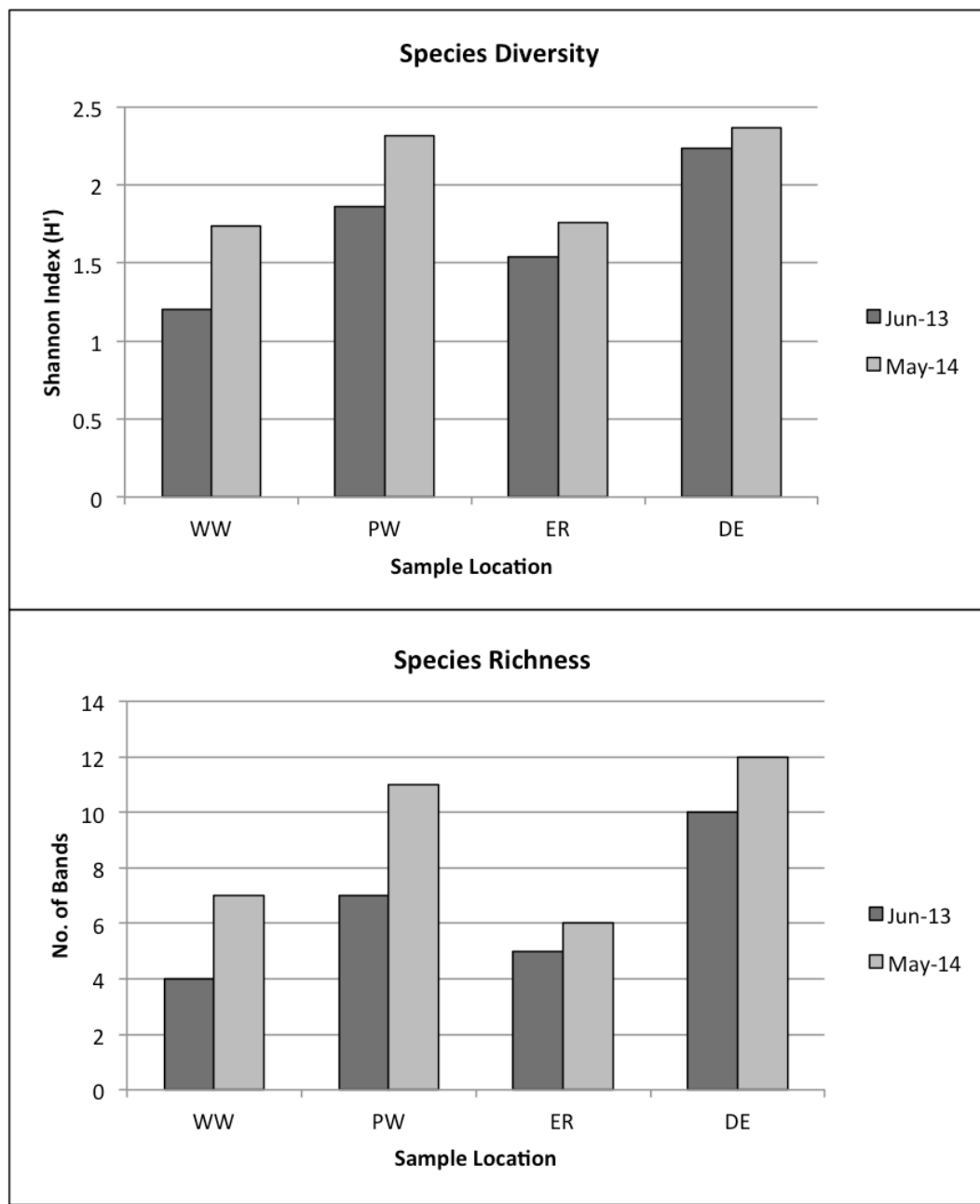

-PW-pond water, WW-well water, ER-early rear water, DE-discharge effluent

Figure 3.11. DGGE-based community analysis of FTS-B samples obtained according to sampling location within the system and date, including (A) species diversity calculated using the Shannon Index (H') and (B) species richness as interpreted by number of bands within each sample.

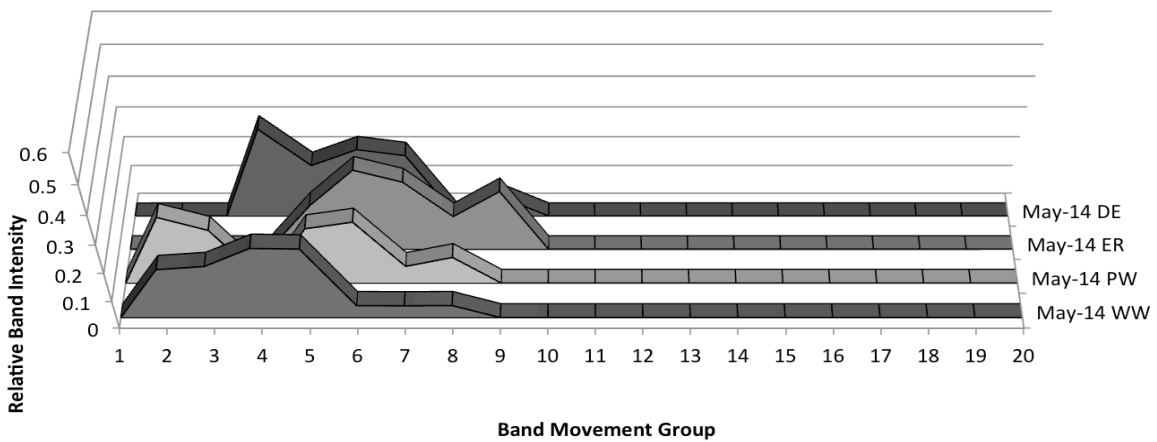
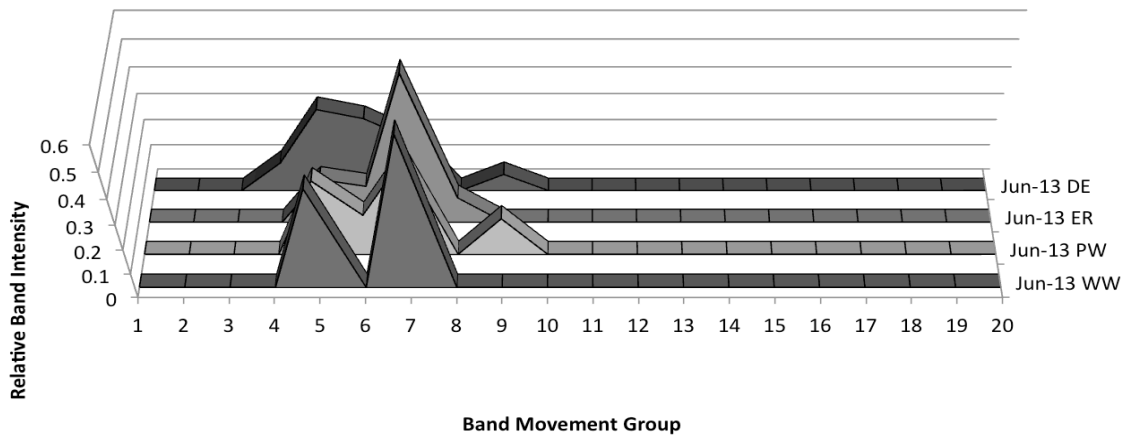

-PW-pond water, WW-well water, ER-early rear water, DE-discharge effluent

Figure 3.12. DGGE-based averaged banding patterns generated for sampling locations of the FTS-B during two summer sampling events in June 2013 (top) and May 2014 (bottom).

Chapter 4: Results for Recirculating Systems

4.1 *E. coli*, *Enterococcus* spp. and Heterotrophic Plate Count Enumerations

Cultureable *E. coli*, *Enterococcus* spp. and total heterotrophic bacteria counts from various locations within the pilot-scale systems were enumerated over the experimental monitoring period to assess the presence and persistence of fecal indicator organisms and overall bacteriological quality of rearing water exposed to the water treatment technologies, respectively. In this way, the overall microbial health of the system could be measured, providing an indication of the sustainability of the cultureable heterotrophic portion of the microbial community and an estimation of spatial distribution.

RAS-A: Nano-Membrane Bioreactor Treated System

The fecal indicator bacteria *E. coli* and *Enterococcus* spp. were detected only twice among all sampling events, and in concentrations below the statistically relevant range. Therefore, culture-based enumeration results for these fecal indicator bacteria are not included within this document. Additionally, it should be noted that concentrations of indicator organisms and HPCs from the biofilm sample are absent for the week 7 sampling event, as the sample was contaminated during transport.

Samples of the receiving influent water, NMB biofilm, and NMB treated effluent were collected for enumeration. A summary of total cultureable heterotrophic counts for each source is depicted in Figure 4.1. Results are presented as colony forming units (CFUs) per mL. Overall, the average concentration for total heterotrophs within RAS-A were consistently highest within biofilm samples during all sampling dates, reaching concentrations of 10^8 CFU/mL, approximately one to two orders of magnitude greater than water samples from

influent and effluent locations. A one log reduction was observed during the sampling event on week 8, followed by a subsequent gradual increase to prior concentrations. In comparison, the average concentration for total heterotrophic bacteria within influent communities ranged between 10^6 to 10^7 CFU/mL over the monitoring period, displaying minimal variation between sampling dates. HPC loads for effluent communities displayed a generally increasing trend up until week 7, peaking at approximately 10^7 CFU/mL, after which concentrations were reduced by two orders of magnitude. Effluent HPC loads were then maintained between 10^5 to 10^6 CFU/mL until the conclusion of the monitoring period. Overall, the NMB appeared to generally reduce influent heterotrophic loads by one to two orders of magnitude from influent concentrations.

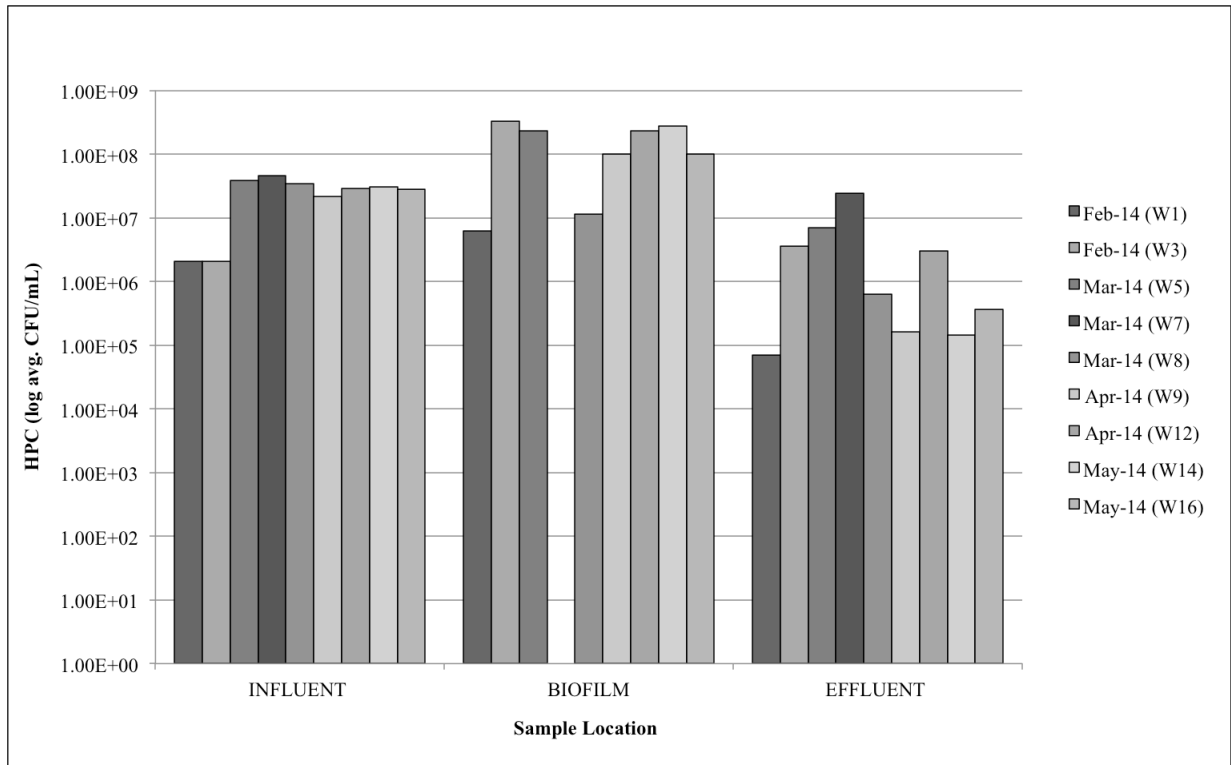

Figure 4.1. Representation of total cultureable heterotrophic plate counts (HPCs) as colony-forming units (CFUs) per mL over the sampling dates within the nano-membrane bioreactor (NMB) pilot-scale system. The sampling week listed corresponds to various sampling dates in the 16-week monitoring period between February and May 2013.

RAS-B: Ultra-Filtration Treated System

Overall, the cultureable fecal indicator organisms *E. coli* and *Enterococcus* spp. were detected in RAS-B on a single sampling event, and in concentrations below the statistically relevant range. Therefore, culture-based enumeration results for these indicator organisms are not included within this document.

To complement the culture-based detection of indicator organisms, the enumeration of the cultureable heterotrophic fraction of the microbial community was performed over the course of the monitoring period (Figure 4.2). Overall, HPC loads were relatively high, in the range of 10^8 CFU/mL or lower over the course of the system sampling locations. Similar to the trend observed for RAS-A, influent source water samples were in the order of 10^6 to 10^7 CFU/mL over the course of the monitoring period. There were some general trends with respect to heterotrophic bacteria concentration following exposure to pre-filter mechanical screening and ultra-filter technology that need mention. Overall, the UF achieved, on average, complete log removal of cultureable heterotrophic bacteria following exposure, such that non-detectable loads were present in in permeate water samples. However, a spike in HPC counts in UF filtrate samples was observed towards the end of the monitoring period during week 10, in the order of approximately 10^4 CFU/mL. Following backwashing of the UF during the sampling events on weeks 5, 10 and 14, HPC loads were in the order of 10^6 , 10^8 and 10^7 CFU/mL, respectively. The biofilm tank provided a unique opportunity to investigate the heterotrophic community trends following exposure to ultra-filtration. Cultivation results for HPCs following removal of suspended substrata revealed values between 10^3 to 10^5 CFU/mL.

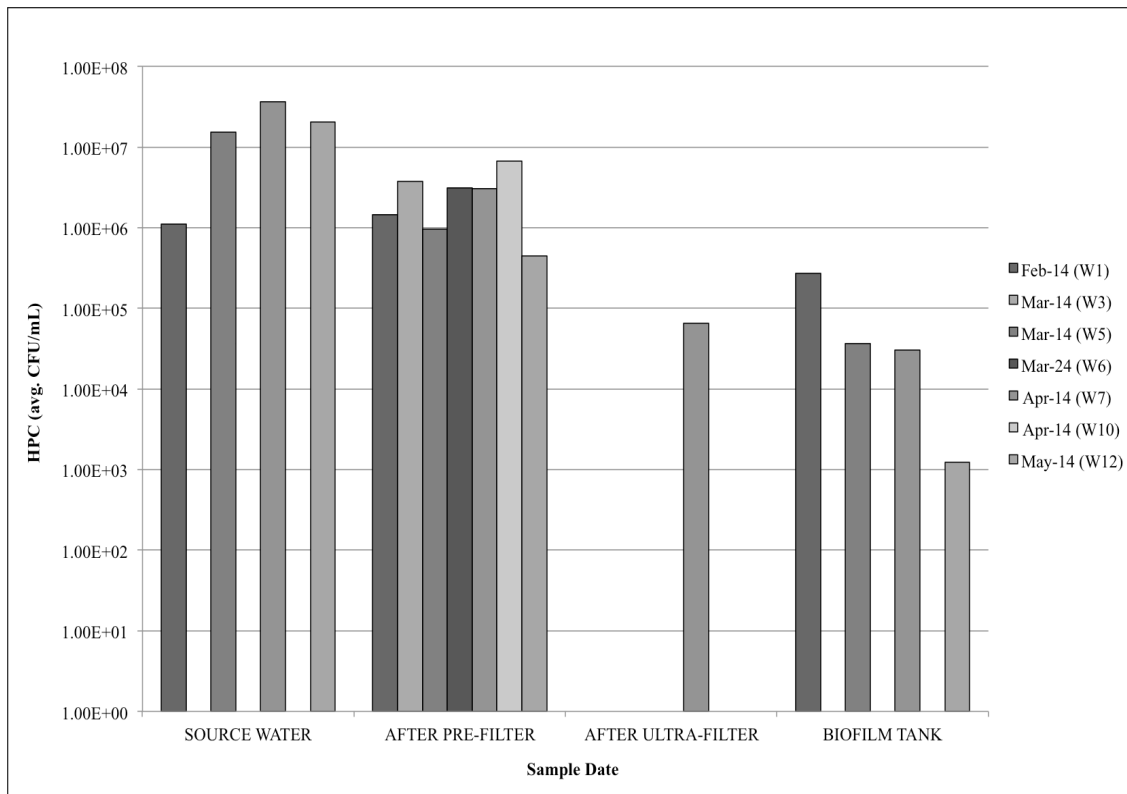

Figure 4.2. Representation of total culturable heterotrophic plate counts (HPC) as colony-forming units (CFUs) per mL over the sampling dates within a recirculating aquaculture system employing ultra-filtration technology. The sampling weeks listed corresponds to various dates between February and May 2013.

4.2. Enumeration of Select Fish Pathogens in a Pilot-Scale Recirculating Aquaculture Systems Utilizing Water Treatment Technologies

With the use of selective and differential media, the enumeration of cultureable pathogenic microorganisms from the genera *Yersinia* and *Aeromonas* were successfully isolated from water samples within two pilot-scale recirculating aquaculture systems for independent and comparative culture-based characterization. This also provided an opportunity to investigate spatial variation in pathogen loads, with particular focus on the implications for persistence and pathogen removal by wastewater treatment technologies. A collective summary of the number of bacterial species isolated from each pilot-scale RAS is depicted in Table 4.1.

Table 4.1. Summary of the total number of *Yersinia* spp. and *Aeromonas* spp. isolated cultivated from the two pilot-scale recirculating systems, RAS-A and RAS-B over the respective experimental monitoring periods.

Sampling Site	Sample Date	Total Number of Environmental Isolates	
		<i>Yersinia</i> spp.	<i>Aeromonas</i> spp.
RAS-A (NMB Treated System)	February 6 th , 2014 (Week 1)	26	12
	February 20 th , 2014 (Week 3)	27	10
	March 4 th , 2014 (Week 5)	50	9
	March 18 th , 2014 (Week 7)	35	12
	March 24 th , 2014 (Week 8)	30	10
	April 1 st , 2014 (Week 9)	20	10
	April 21 st , 2014 (Week 12)	30	10
	May 6 th , 2014 (Week 14)	35	10
	May 22 nd , 2014 (Week 16)	20	10
	Total	273	93
RAS-B (UF Treated System)	February 20 th , 2014 (Week 1)	30	19
	March 18 th , 2014 (Week 3)	31	5
	March 25 th , 2014 (Week 5)	40	10
	April 1 st , 2014 (Week 7)	10	5
	April 22 nd , 2014 (Week 10)	20	10
	May 6 th , 2014 (Week 12)	50	10
	May 22 nd , 2014 (Week 14)	19	10
	Total	200	69

RAS-A: Nano-Membrane Bioreactor Treated System

Cultureable *Yersinia* spp. and *Aeromonas* spp. from various sampling points within the pilot-scale system were enumerated over the course of sixteen weeks to evaluate the occurrence, distribution and persistence of common fish pathogens in a RAS employing a NMB for water treatment. Results for total cultureable *Yersinia* spp. grown on YSA from specified sampling points are reported in Figure 4.3A, as well as cultureable loads of *Aeromonas* spp. grown on ADA (Figure 4.3B). Bacterial abundances are reported as colony forming units per 100 mL.

Pathogen concentrations were relatively consistent among sample locations throughout the course of the experimental period. Specifically, initial reference levels of *Yersinia* spp. from influent water samples were in the order of 10^5 to 10^6 CFU/100 mL. Biofilm samples obtained from within the NMB generally displayed the highest viable counts for *Yersinia* spp. compared to influent and effluent samples. In particular, the average concentration of *Yersinia* spp. in the biofilm samples ranged from 10^7 to 10^8 CFU/100 mL, with a slight peak observed in viable counts during week 8, after which counts decreased by one order of magnitude and were maintained at 10^7 CFU/100 mL for the remainder of the monitoring period. Overall, the NMB appeared to reduce *Yersinia* spp. loads one to two orders of magnitude from influent to effluent samples, with final effluent concentrations between 10^3 to 10^4 CFU/ 100 mL.

In comparison, viable counts for *Aeromonas* spp. remained significantly lower than *Yersinia* spp. concentrations throughout all sampling weeks, with highest concentrations reaching 10^4 CFU/100 mL. Little to no variation was observed between the concentrations of *Aeromonas* spp., with the greatest overall location-dependent variation observed in the biofilm samples. Influent loads were in the order of 10^3 CFU/100 mL throughout the monitoring

period, while biofilm samples were approximately one order of magnitude higher, in the order of 10^4 CFU/100 mL. Similar to *Yersinia* spp. abundances, effluent samples indicated a reduction in *Aeromonas* spp. loads following exposure to the NMB, with final concentrations approximately one order of magnitude (10^2 CFU/100 mL) lower compared to influent samples.

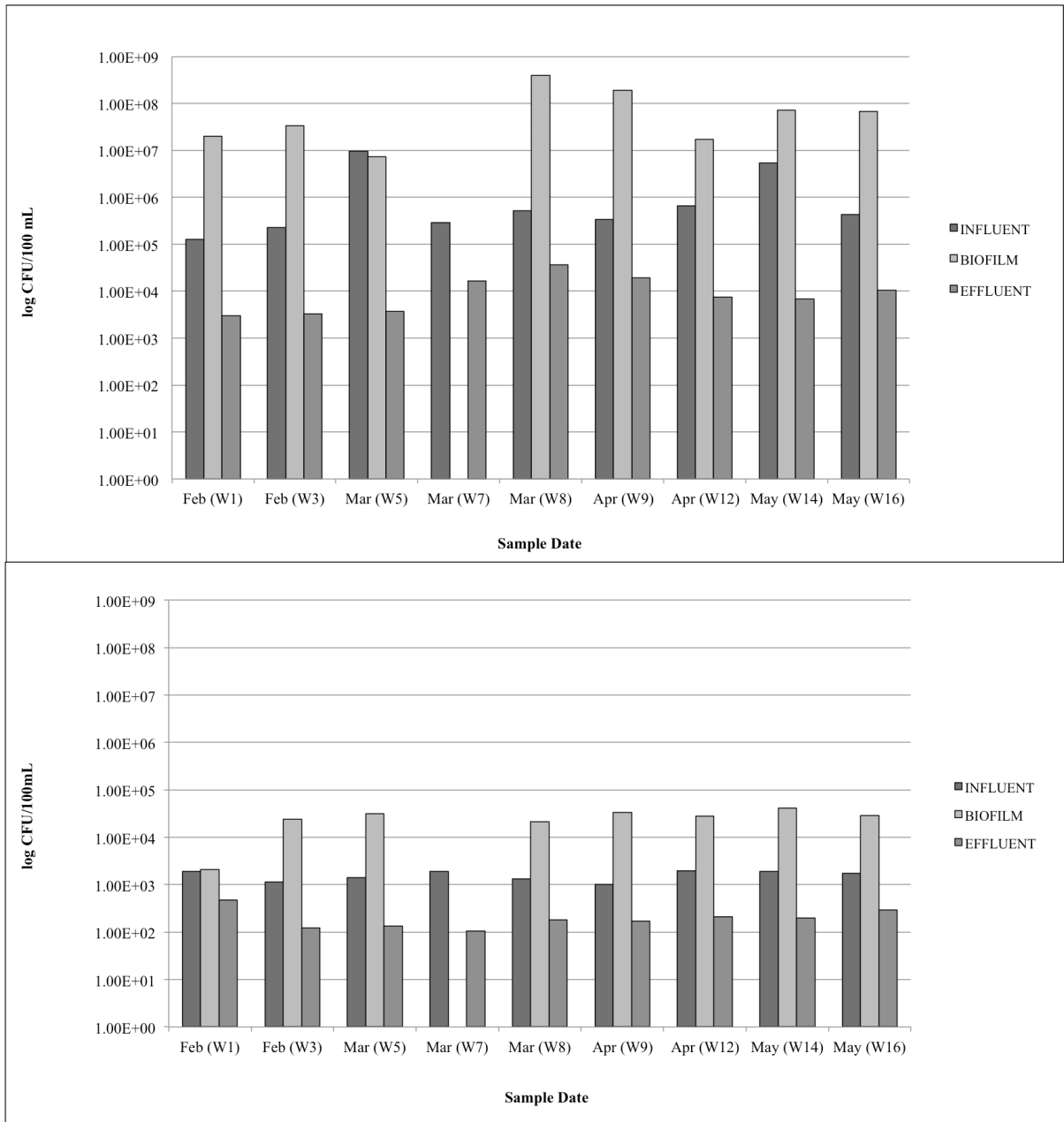

Figure 4.3. Enumeration results of total culturable *Yersinia* spp. (A) and *Aeromonas* spp. (B) as colony-forming units (CFUs) per 100 mL from respective sampling locations in a pilot-scale recirculating aquaculture system employing a nano-membrane bioreactor (RAS-A). The sample weeks listed corresponds to various dates within the 16-week monitoring period that occurred between February and May 2014.

RAS-B: Ultra-Filtration Treated System

Initial reference levels of *Yersinia* spp. from RAS-B source water sampled were in the order of 10^5 to 10^6 CFU/100 mL over the course of the monitoring period (Figure 4.4A). Source water containing suspended substratum represented an increase in *Yersinia* spp. concentrations to 10^7 CFU/100 mL, one to two orders of magnitude higher than source water samples obtained without the substrate media. Generally, reduction in *Yersinia* spp. loads did not occur to any great extent until exposure to the ultra-filter (UF). The UF technology achieved, on average, up to 5 log reductions, such that complete log removal of *Yersinia* spp. following exposure was evident. Interestingly, across all sampling events in the monitoring period, enumeration results of *Yersinia* spp. concentrations within the biofilm tank displayed a log increase of two to three orders of magnitude, indicating recovery and accumulation of pathogens within the filtrate in the biofilm tank (reservoir). Generally, the pre-filter was able to reduce *Yersinia* spp. loads by approximately one order of magnitude.

Comparably, total *Aeromonas* spp. loads enumerated from RAS-B were lower than *Yersinia* spp., in the range of 10^3 CFU/100 mL or lower over the course of the system for all sampling events in the monitoring period (Figure 4.4B). Minimal variation was observed for *Aeromonas* spp. cultivated from source water throughout the monitoring period, with concentrations remaining stable at approximately 10^3 CFU/100 mL. In comparison, source water containing suspended substratum generally displayed a two-log increase in *Aeromonas* spp. compared to source water samples obtained without the substrate media. Pathogen accumulation and reduction trends observed for *Yersinia* spp. were similarly observed for *Aeromonas* spp. Generally, the UF achieved, on average, complete log removal of cultureable *Aeromonas* spp. from the system following exposure. Notably, biofilm tank sample

enumerations of *Aeromonas* spp. similarly reflected the trend observed for *Yersinia* spp., whereby log increases of two orders of magnitude were observed for cultureable *Aeromonas* spp., reaching final concentrations of 10^2 CFU/100 mL.

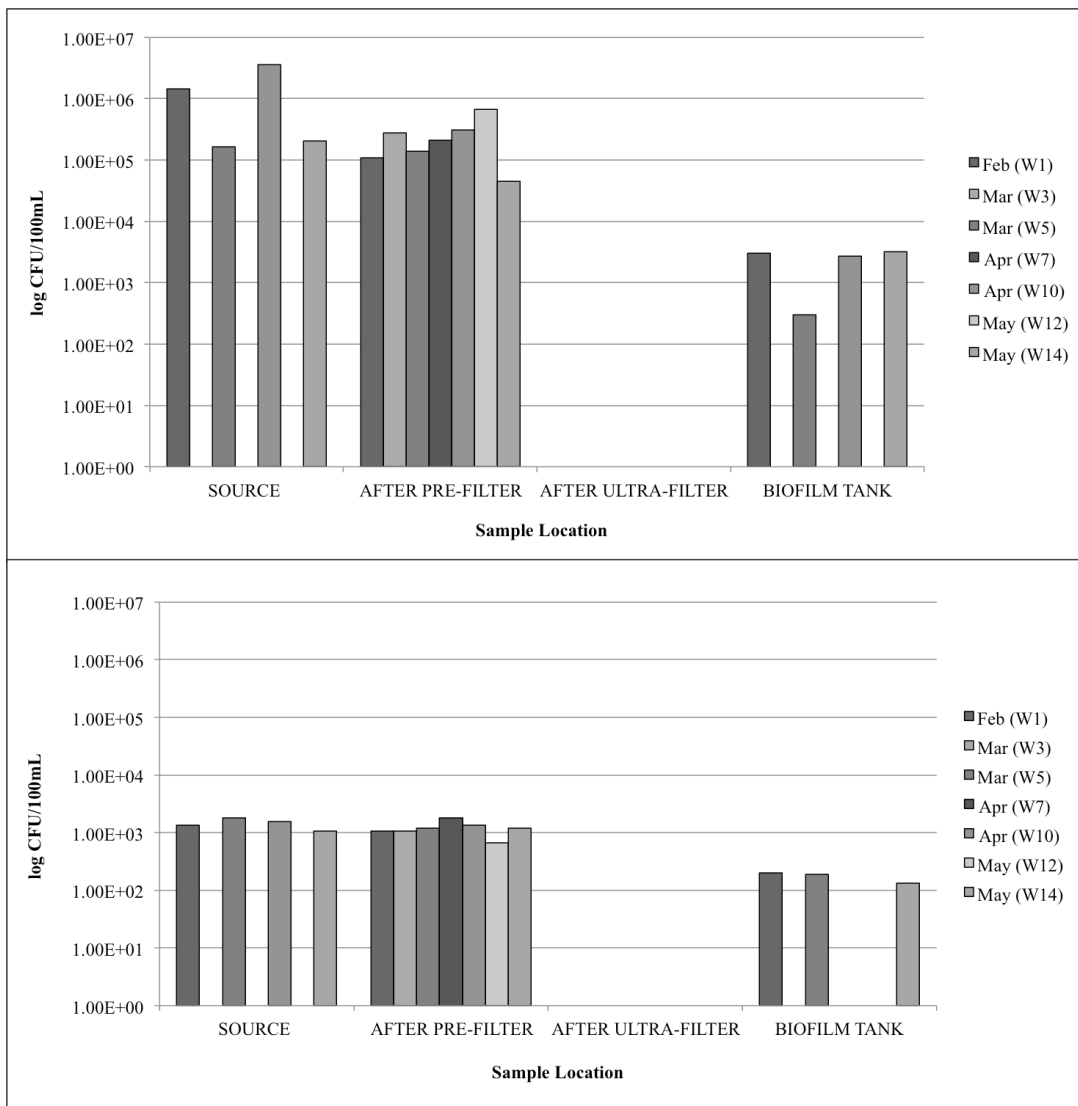

Figure 4.4. Enumeration results of total culturable *Yersinia* spp. (A) and *Aeromonas* spp. (B) as colony-forming units (CFUs) per 100 mL from respective sampling locations in a pilot-scale recirculating aquaculture system employing an ultra-filtration technology (RAS-B). The sample weeks listed corresponds to various dates within the 16-week monitoring period that occurred between February and May 2014.

4.2.1 Qualitative PCR to Confirm and Characterize *Yersinia* spp. and *Aeromonas* spp.

RAS-A: Nano-Membrane Bioreactor Treated System

Genotypic confirmation using qualitative PCR was performed on a total of 273 presumptive *Yersinia* spp. isolates and 93 presumptive *Aeromonas* spp. isolates, collected from sampling locations within the pilot-scale RAS over the 16-week monitoring period. Specifically, *Yersinia* spp. isolates were characterized using species-specific PCR in order to distinguish between *Y. ruckeri* and *Y. enterocolitica*, as genus-specific PCR primers for *Yersinia* spp. have not previously been developed. Table 4.2 summarizes these results. Among the total number of screened presumptive *Yersinia* spp. isolates (n=273), 39.6% (108/273) were genotypically confirmed as *Y. enterocolitica*, while only 1% (3/273) were characterized as *Y. ruckeri*. Similarly, genotypic confirmation of presumptive *Aeromonas* spp. isolates was performed using genus-specific PCR primers of the gene *gyrB*, which has previously been designed for confirmation of the genus *Aeromonas* (Yanez *et al.*, 2003). In total, 93 presumptive isolates were screened, with 66.7% (63/93) confirmed as *Aeromonas* spp.

Table 4.2. Molecular confirmation of presumptive *Aeromonas* spp. isolates and distribution of *Y. enterocolitica* and *Y. ruckeri* among screened isolates cultivated from the pilot-scale RAS utilizing NMB technology.

Species	Total # of Isolates Screened	Confirmed +ve by PCR	% Confirmation
<i>Y. enterocolitica</i>	273	(108/273)	39.6%
<i>Y. ruckeri</i>	273	(3/273)	1.0%
<i>Aeromonas</i> spp.	93	(63/93)	66.7%

RAS-B: Ultra-Filtration Treated System

Table 4.3 summarizes the results of genotypic confirmation performed on a total of 200 presumptive *Yersinia* spp., and 69 presumptive *Aeromonas* spp. isolates using qualitative PCR. The characterization of *Yersinia* spp. isolates was accomplished using species-specific PCR to distinguish between *Y. ruckeri* and *Y. enterocolitica*. Among the total number of screened presumptive *Yersinia* spp. isolates (n=200), only 3% (6/200) were characterized as *Y. ruckeri*, while 49% (98/200) were confirmed as *Y. enterocolitica*. Correspondingly, genotypic confirmation of presumptive *Aeromonas* spp. isolates was performed using genus-specific PCR primers of the gene *gyrB*. Of the 69 presumptive isolates were screened, 71% (49/69) were genotypically confirmed as members of the genus *Aeromonas*.

Table 4.3. Molecular confirmation of presumptive *Aeromonas* spp. isolates and distribution of *Y. enterocolitica* and *Y. ruckeri* among screened isolates cultivated from the pilot-scale RAS utilizing UF technology.

Species	Total # of Isolates Screened	Confirmed +ve by PCR	% Confirmation
<i>Y. enterocolitica</i>	200	(49/200)	49.0%
<i>Y. ruckeri</i>	200	(6/200)	3.0%
<i>Aeromonas</i> spp.	93	(49/69)	71.1%

4.3 Community-Level Physiological Profiling of Communities from Pilot-scale Recirculating Aquaculture Systems

In addition to tracking the overall cultureable fraction of the community using a traditional culture-based approach, Biolog EcoPlates™ were utilized to characterize the microbial communities within different spatial regions in the pilot-scale recirculating systems, RAS-A and RAS-B, based on sole carbon source utilization patterns.

RAS-A: Nano-Membrane Bioreactor Treated System

Figure 4.5 summarizes the average well colour development (AWCD), functional diversity (H') and substrate richness (R) determined for all RAS-A water samples over the monitoring period. Across all stages of the system, biofilm communities within the NMB more readily metabolized the carbon substrates provided in the EcoPlate™ than did the influent and effluent planktonic communities, based on AWCD trends (Figure 4.5A). Generally, a reduction in metabolic capabilities was observed in effluent communities following exposure to the NMB. Furthermore, from the onset of monitoring, the AWCD for BF communities increased until week 9, after which carbon substrate consumption stabilized at an absorbance value of approximately 1 at 590 nm. Comparatively, influent communities demonstrated slightly higher carbon substrate metabolic rates than effluent communities, with the exception of the communities sampled during week 9, whereby effluent communities displayed considerably higher rates of carbon metabolism than influent communities.

Metabolic diversity analysis based on the Shannon Index (H'), which takes into consideration both the number of carbon substrates utilized, as well as the degree of utilization as measured spectrophotometrically, revealed minimal variations in community diversity between the influent, biofilm, and effluent communities throughout the monitoring period

(Figure 4.5B). Functional diversity values (H') ranged from 3.2 to 3.4 throughout all sampling locations, with biofilm samples generally displaying slightly greater functional diversity compared to influent and effluent communities. Notably, the biofilm community sampled during week 8 demonstrated a substantial loss of diversity to an H' value of 3.2. Recovery in diversity was evident following this event, with a generally increasing trend in functional diversity observed for the remainder of the monitoring period. Minimal variation was observed between the RAS-A communities in terms of metabolic richness, or the total number of carbon substrates metabolized resulting in an absorbance reading of 0.25 or greater, across the monitoring period (Figure 4.5C). At the onset of the monitoring period, the biofilm and effluent communities were only able to utilize 23 and 24 of the 31 provided carbon sources, respectively. Conversely, the microbial community within the influent sample was able to utilize all 31 carbon sources provided in the EcoPlateTM. Generally, a pseudo-steady state value was reached by week 8 of monitoring, with communities from all sampling locations expressing the capacity to utilize all 31 carbon sources following an incubation period of 96 hrs.

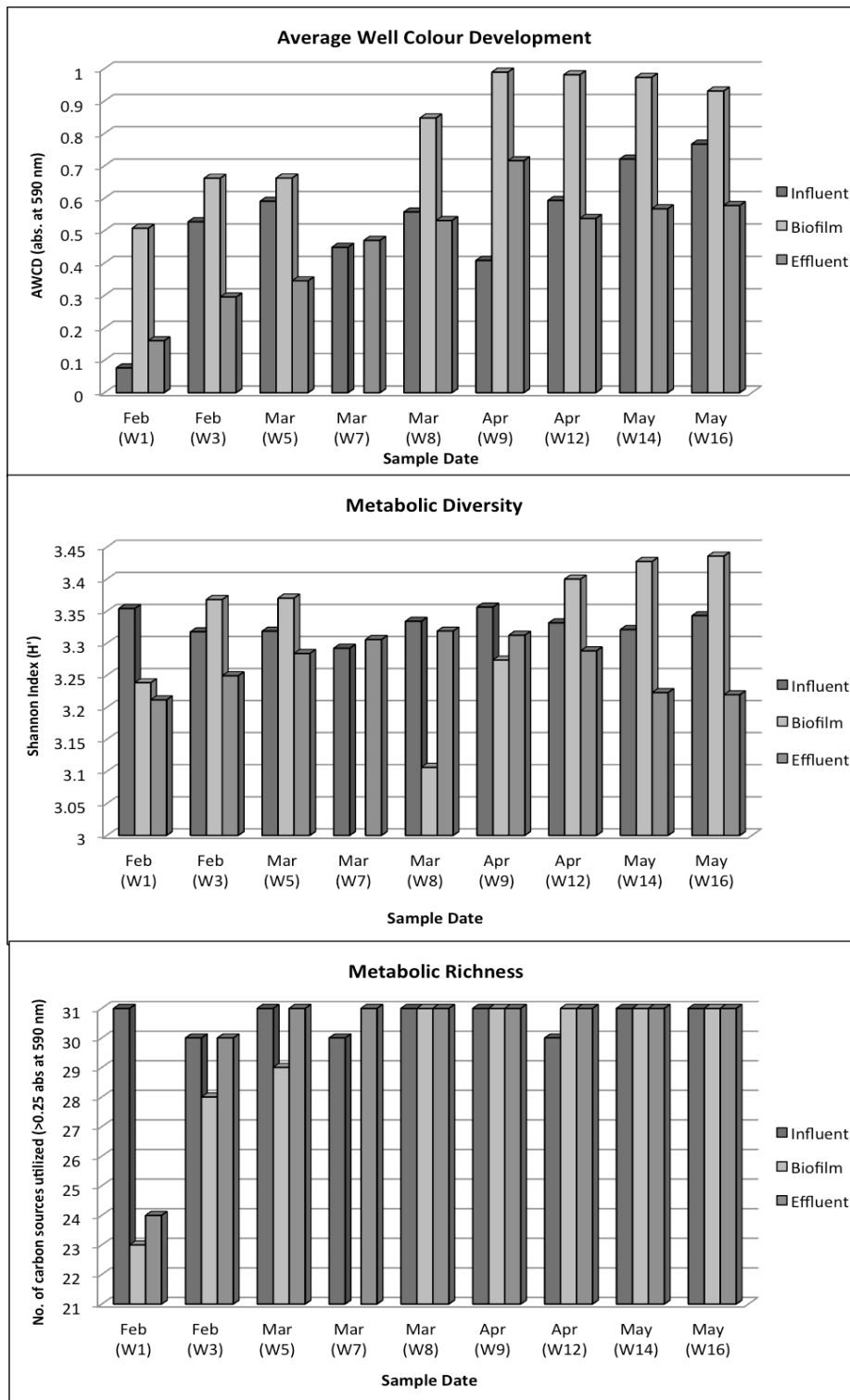
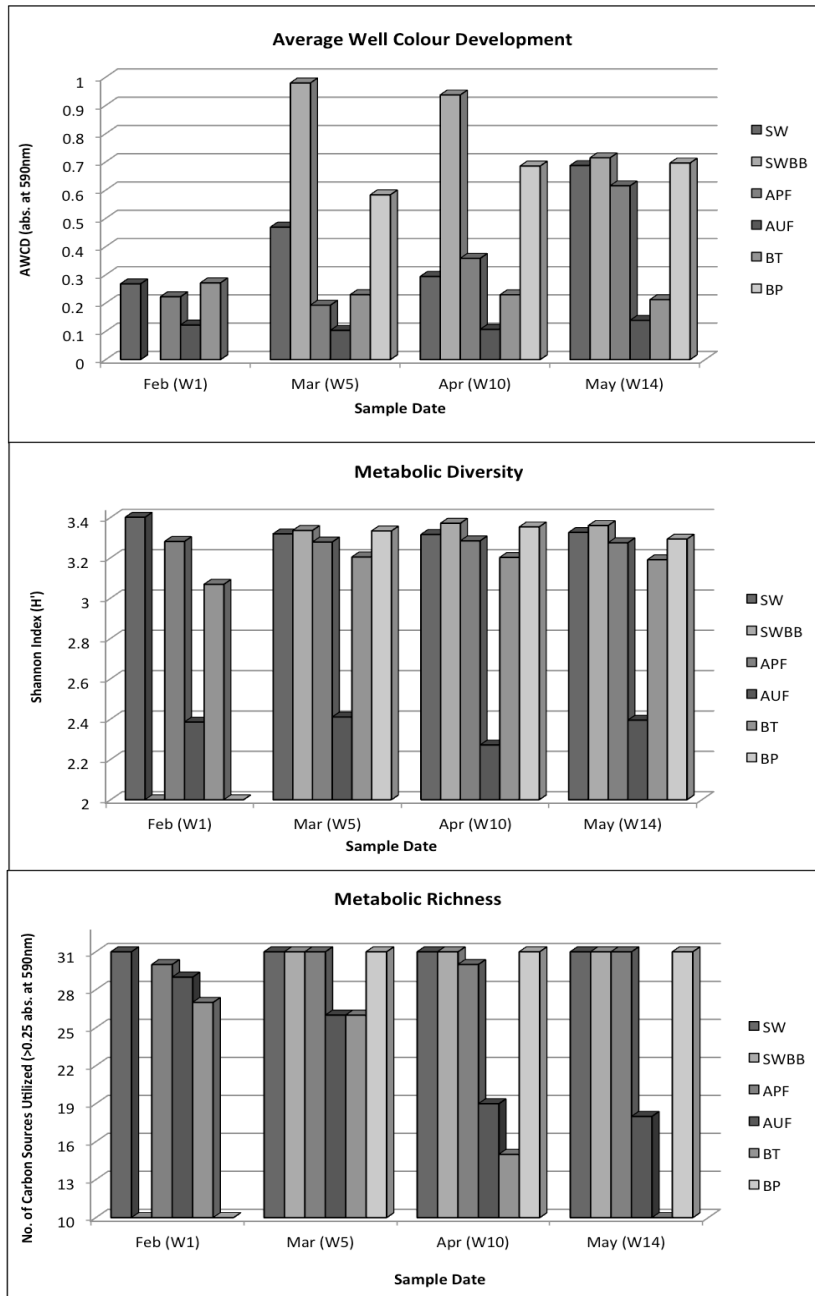

Figure 4.5. Community-level physiological profiles (CLPP) of microbial communities from the pilot-scale RAS utilizing NMB technology based on (A) average well colour development, (B) metabolic diversity and (C) metabolic richness following a 96 hr incubation period.

RAS-B: *Ultra-Filtration Treated System*

As is evident in Figure 4.6A, microbial communities obtained from RAS-B demonstrated considerable variations in metabolic rates with regard to sampling location within the system. Based on AWCD trends, the microbial communities extracted from samples prior to the UF technology display different capacities to metabolize the provided carbon substrates than communities extracted post-treatment exposure. Specifically, the source water sample containing suspended substrata generally displayed the highest metabolic rates of carbon utilization, with OD_{590nm} readings of 0.7 and greater. Comparatively, AWCD values for the planktonic community within source water were significantly lower among all sampling events (Figure 4.6A). While slight decreases in metabolic rates were observed in communities following exposure to the pre-filter, a significant reduction in metabolic capability was consistently observed for communities following exposure to the UF, followed by a recovery in functionality in the biofilm tank. Following backwashing of the UF membrane core (week 5, 10, and 14), extracted communities displayed metabolic rates greater than those of source water communities. Functional diversity trends, as expressed by the Shannon Index (H'), revealed that high diversity was generally sustained throughout the length of the monitoring period, with H values ranging from 3.28 to 3.4 for all communities obtained from respective locations (Figure 4.6B). However, an apparent trend was evident with regard to metabolic diversity, whereby a significant loss of functional diversity was observed in samples from the outlet of the UF, and then recovered in the biofilm tank. Overall, an interesting trend was apparent with regard to measured metabolic richness for the RAS-B communities. With the exception of samples obtained from the ultra-filter outlet and biofilm tank, all microbial communities expressed the capacity to utilize all 31 provided carbon sources following an

incubation period of 96 hrs (Figure 4.6C). Conversely, communities extracted from the ultra-filter outlet and biofilm tank demonstrated a generally decreasing trend in metabolic richness, with richness values decreasing below 20 by the end of the monitoring period.



-Source water (SW); suspended substratum (SWBB); after pre-filter (APF); after ultra-filter (AUF); backwash port (BP) and biofilm tank (BT)

Figure 4.6. Community-level physiological profiles (CLPP) of microbial communities from the pilot-scale RAS utilizing UF technology based on (A) average well colour development, (B) metabolic diversity and (C) metabolic richness following a 96 hr incubation period.

4.4 Structural Fingerprinting of Microbial Communities in a RAS using PCR-DGGE

DGGE fingerprinting was completed for all samples obtained from RAS-A and RAS-B, resulting in a total n= 26 and n=27 samples, respectively.

RAS-A: Nano-Membrane Bioreactor Treated System

DGGE structural fingerprints were successfully generated from all DNA samples obtained from respective locations within RAS-A over the monitoring period. Species diversity, a proportional measure of the richness and evenness of a sample defined by the Shannon Index (H'), was calculated for each of the microbial communities obtained (Figure 4.7A). Overall, the greatest community diversity within each of the respective sampling locations was observed in sessile communities obtained from the NMB, with H' values of 2.5 or greater. Genetic diversity was maintained within these communities throughout the monitoring period, with only minor fluctuations evident. From the onset of the monitoring period until week 3, influent and effluent communities demonstrated equal structural diversity, with values of 2.1. Following the week 3 sampling event, a divergence in genetic diversity was observed among the respective communities. A decrease in structural diversity was most notably observed in effluent communities over the remainder of the monitoring period, with values ranging from approximately 1.6 to 2.0. Conversely, the diversity of influent communities demonstrated a slight increase in diversity that was generally maintained until the conclusion of the experimental period.

Species richness, defined as the number of bands above background representing operational taxonomic units (OTUs), is presented in Figure 4.7B. The number of bands detected in the DGGE fingerprints within a given sample was not consistent among the experimental period. For instance, exposure to the NMB appeared to decrease the complexity

of the communities, as revealed by effluent richness values compared to influent communities. In general, biofilm samples obtained from the NMB consistently displayed the greatest structural richness, with OTU values ranging from 16 to 20 over the monitoring period. In comparison, influent community OTUs displayed a range from 10 to 15, while the effluent community displayed the lowest genetic richness of approximately 7 to 10 OTUs.

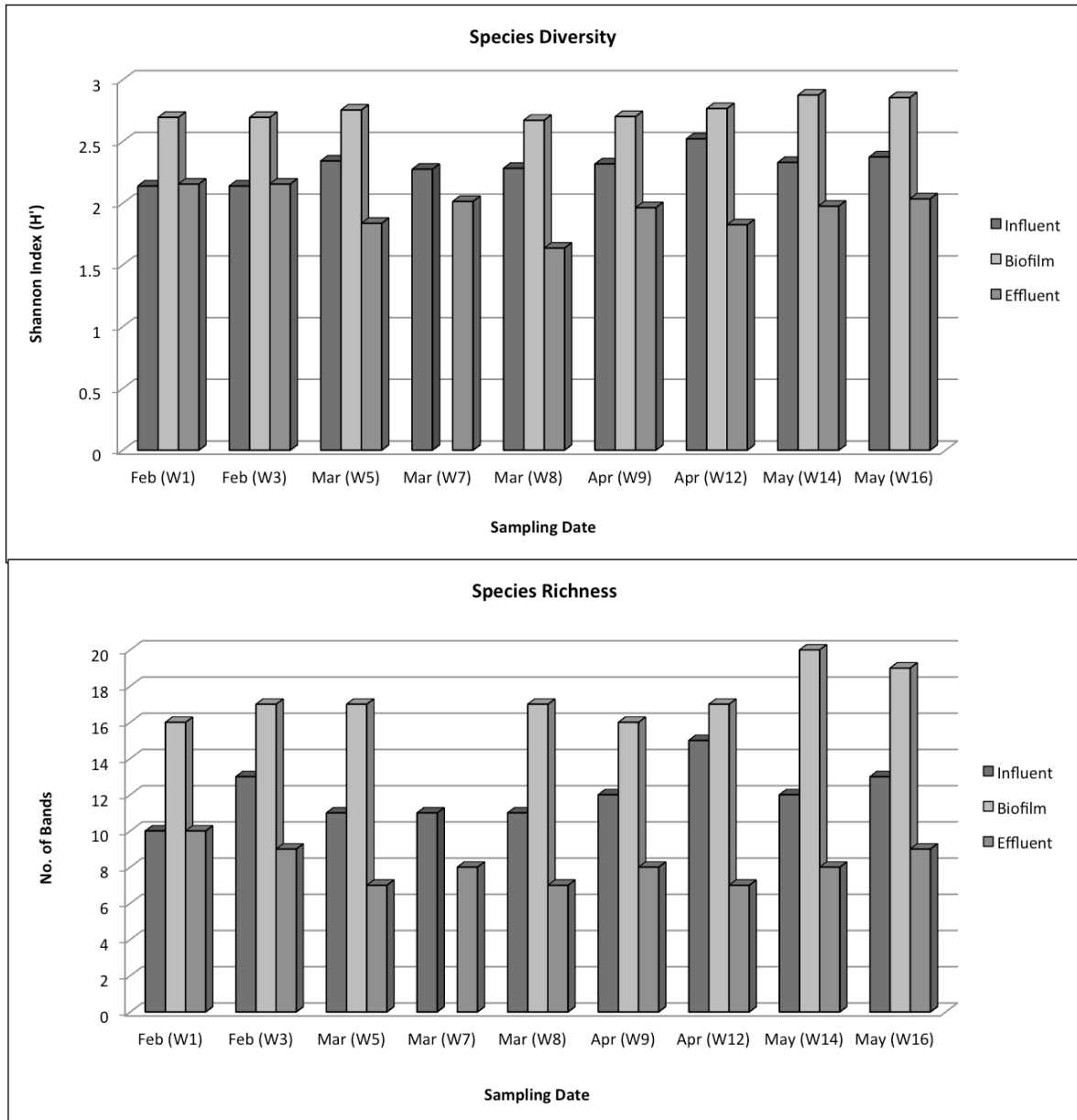
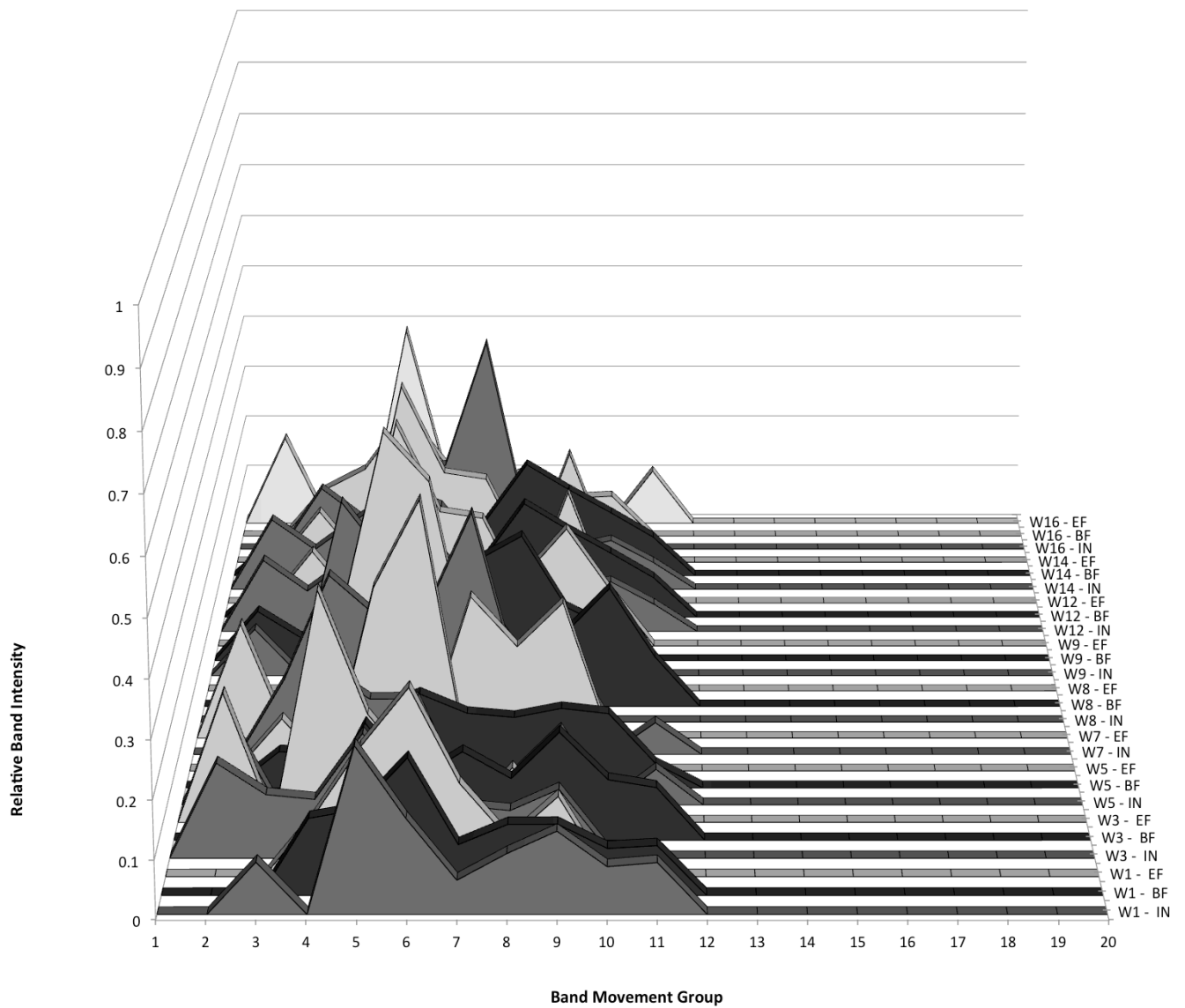

Figure 4.7. DGGE-based community analysis of the nano-membrane bioreactor treated system (RAS-A) samples collected over the duration of the 16-week monitoring period from February to May 2014, including (A) species diversity calculated using the Shannon Index (H') and (B) species richness as interpreted by number of bands representing operational taxonomic units (OTUs) within the respective sample.

According to the average banding plot illustrated in Figure 4.8, similar genetic profiles were observed among respective locations sampled within the RAS. Notably, the greatest diversity of OTUs based on the distribution of band movement groups was observed within biofilm samples collected from the NMB, consisting primarily of two to four moderate peaks contained within the 4th and 12th band movement group. Effluent communities were composed predominantly of moderately low G+C content. Generally, a dominant peak was observed between the 4th and 9th band movement group, contributing approximately 30 to 50% of the community composition throughout the experimental monitoring period. Comparatively, the appearance and disappearance of high band intensity OTUs was observed for effluent profiles. Interestingly, the community structure of all sampled communities obtained towards the end of the experimental period occupied similar band movement groups



- Influent (IN); biofilm (BF) and effluent (EF)

Figure 4.8. DGGE-based averaged banding plot for all samples obtained throughout the 16-week experimental monitoring period from the pilot-scale recirculating aquaculture system (RAS-A) employing a nano-membrane bioreactor. The sampling weeks listed corresponds to various dates between February and May 2013.

RAS-B: *Ultra-Filter Treated System*

The lowest genetic diversity was observed in samples collected at the outlet of the ultra-filter (depicted as AUF), with H' values consistently below 2.0 throughout the monitoring period (Figure 4.9A). Moreover, a gradual decline in genetic diversity was evident for these samples from the onset of monitoring, followed by an evident increase in diversity within the biofilm tank, where H' values were between 2 and 2.5. The highest species diversity was demonstrated in both the source water samples obtained with suspended substrata (depicted as SWBB), and the samples obtained during backwashing of the UF (depicted as BP). This general trend was further reflected in the richness of the sampled communities across the monitoring period (Figure 4.9B), such that SWBB and BP displayed richness values twice as high compared to AUF, at 15 and 16 OTUs, respectively.

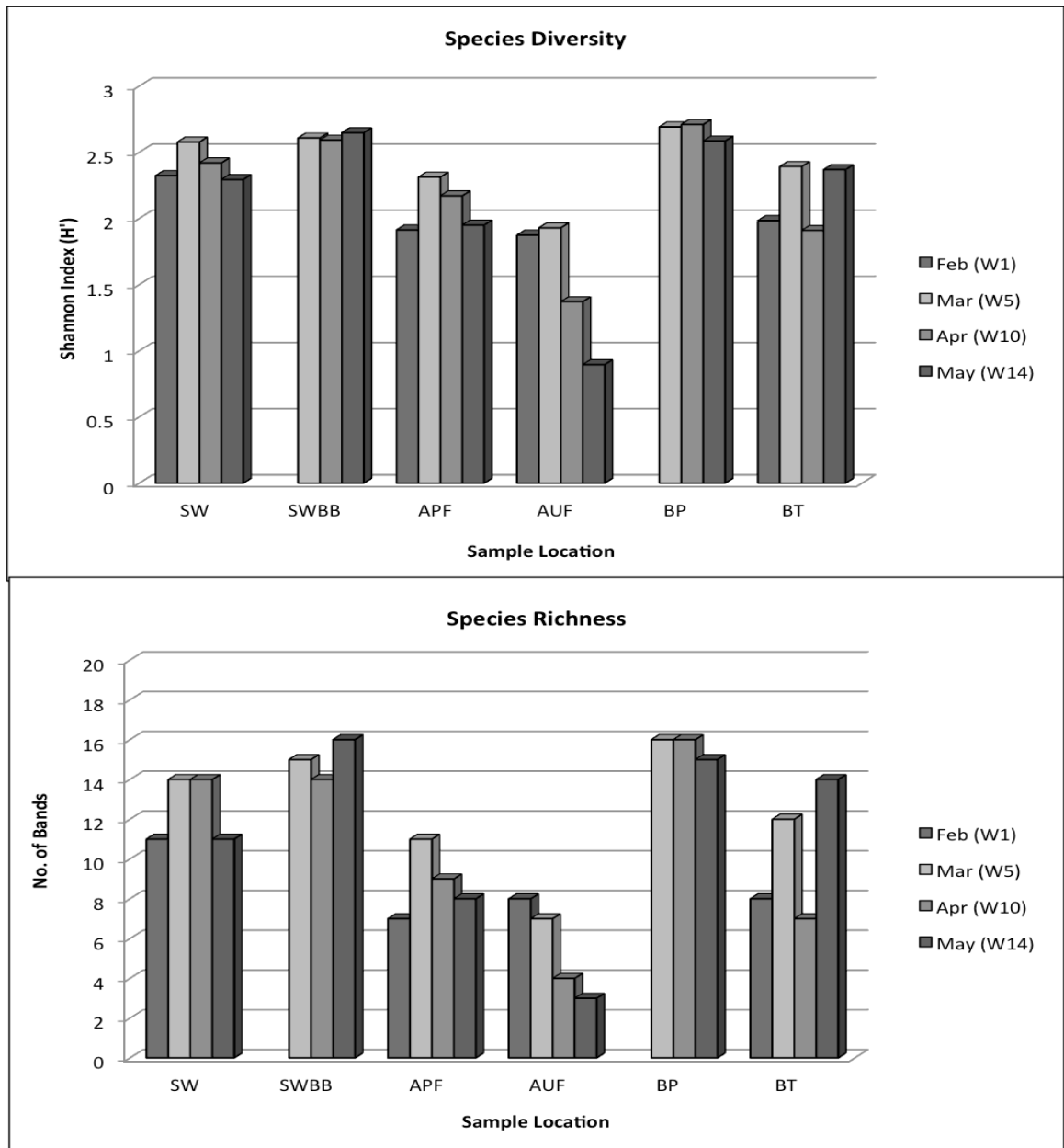

-Source water (SW); suspended substratum (SWBB); after pre-filter (APF); after ultra-filter (AUF); backwash port (BP) and biofilm tank (BT)

Figure 4.9. DGGE-based community analysis of the ultra-filtration treated system (RAS-B) samples collected over the duration of the 16-week monitoring period from February to May 2014, including (A) species diversity calculated using the Shannon Index (H') and (B) species richness as interpreted by number of bands representing operational taxonomic units (OTUs) within the respective sample.

According to the average banding plot for RAS-B, structural profiles for sampled microbial communities were highly varied across the experimental period (Figure 4.10). Profiles were dominated by moderate and high G+C content OTUs, with the emergence and disappearance of discrete peaks throughout the monitoring period. Among all samples, the average distinct peaks ranged from 20% to 60% of the total OTUs for the individual communities collected from each location in the RAS-B. Overall, there was no apparent trend between the DGGE-generated banding profiles for communities extracted from the same locations across the 16-week experimental period.

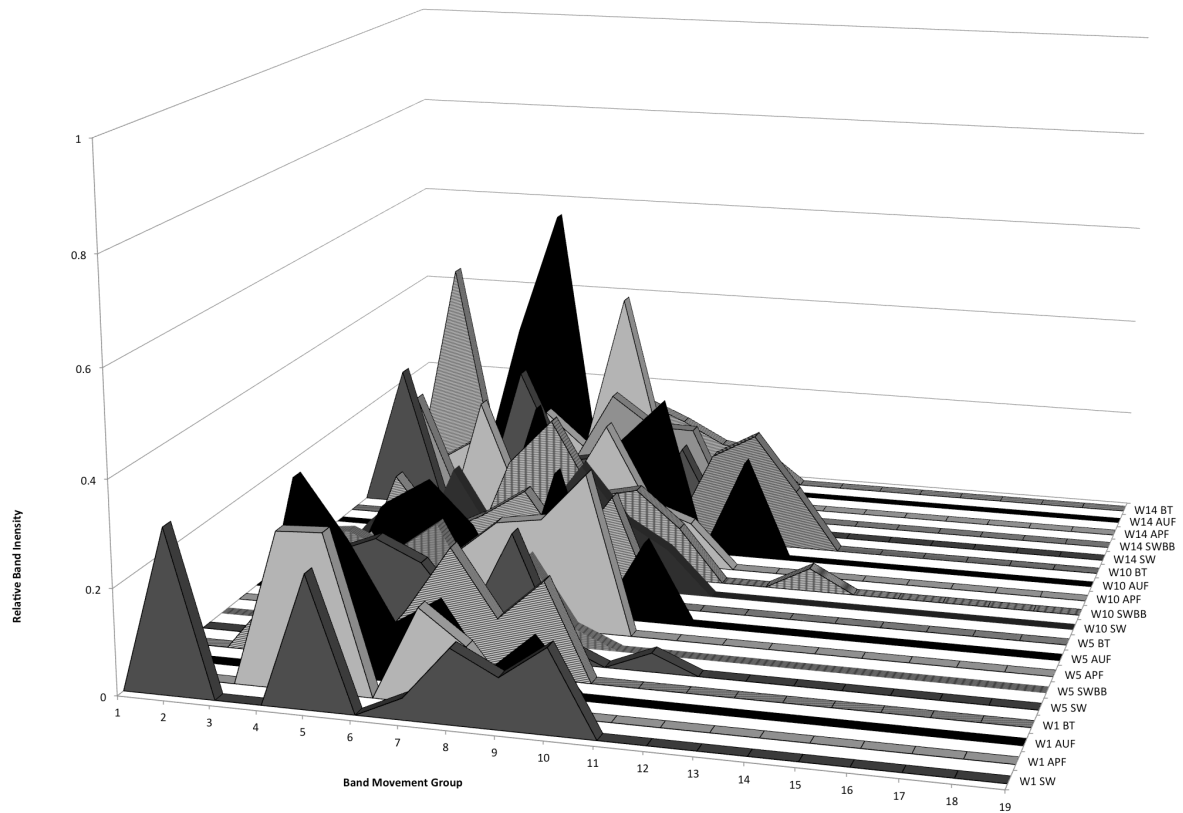

-Source water (SW); after ultra-filter (AUF); after pre-filter (APF); biofilm tank (BT) and source water with bioballs (SWBB)

Figure 4.10. DGGE-based averaged banding patterns generated for sampling locations of the RAS-A and sampling dates for all sampling events in February, March, April and May (2014).

Chapter 5: Discussion

5.1 Comparison of Group Specific Media-based Enumeration and Characterization in Aquaculture Systems of Varying Scale and Design

While aquatic environments have been widely documented to support a diverse composition of microbial species responsible for a multitude of biochemical processes (Blancheton *et al.*, 2013; Pomeroy *et al.* 2007), limited information is available on the enumeration and spatial distribution of microbial communities in highly productive aquaculture ecosystems. In the current study, we attempted to specifically fill this gap, using select microbial groups and a range of media types to enumerate and characterize microbial constituents of interest present within two pilot-scale recirculating (RAS), and two field-scale flow-through aquaculture systems. Specifically, one of the objectives of this study was to develop an understanding of the relative abundances of specific microbial community members in aquaculture systems.

5.1.1 Enumeration and Comparison of the Heterotrophic Communities

Cultivation results from the FTS-A demonstrated clear trends with respect to both seasonality and topography of the system flow path. As is evident in Figure 3.1, heterotrophic plate counts (HPCs) were more frequently detected during sampling events in warmer seasonal months (August 2013 and April 2014), compared to colder climate months (February and November 2013), with the overall highest abundance observed in August at approximately 10^8 CFU/mL. Nonetheless, average HPC abundances remained relatively high during the colder climate months with final concentrations in February and November approximately two orders of magnitude lower, at 10^6 CFU/mL. These results are similar to findings by Lee *et al.* (2002),

who collected water samples from various locations within a fish farm during January, May, August, and November, and found that HPC abundances were highest during warmer climate sampling months. While sampling events for FTS-B were limited to summer months (June 2013 and May 2014), HPC results were comparable to abundances from FTS-A during warm climate sampling (Figure 3.3), with peak abundances of 10^8 CFU/mL observed among both sites.

A number of prevailing conditions may account for these results, and have been extensively documented in literature (Moriarty, 1997). For instance, two of the most critical factors responsible for the growth and control of bacteria in aquatic environments are the concentration of organic substrates readily available (labile vs. recalcitrant), and temperature (Kirchman, 1994). This same author also demonstrated the importance of temperature on bacterial growth by showing that there was a high correlation between growth rate and *in situ* temperature, such that increased temperatures directly corresponded to increased growth rates. Rearing production in the systems typically experiences peak volumes during summer months, contributing to a higher supply of available substrate from the increase in feed quantity, which may favour the proliferation of fast growing opportunistic species (r-strategists) (Blancheton *et al.*, 2013). Moreover, the effect of substrate concentration can be modified by the biochemical composition of the organic matter; in particular, amino acids have been demonstrated to stimulate growth of several species of aquatic microorganisms (Kirchman, 1994). Compound feed for aquaculture practices is primarily composed of protein-rich fishmeal and fish oil as the dominant ingredients (Blacheton *et al.*, 2013), which, following breakdown may contribute to elevated substrate concentrations and promote heterotrophic growth. In this study, a generally increasing trend was observed with regard to water flow through each of the flow-through

systems, such that relative concentrations of heterotrophic bacteria were highest within the treatment pond and polishing locations of FTS-A, and the pond and discharge effluent locations of the FTS-B. These results are important in that relative abundances of 10^7 CFU/mL or greater are being potentially discharged into the receiving environment. In both the water column and sediments of aquatic ecosystems, bacteria are known as the major decomposers of organic matter (van Rijn, 1996). The rapid growth rates and potentially high growth efficiencies of aquatic bacteria have suggested to other researchers that the production of heterotrophic bacterial biomass represents an important link between detritus, dissolved organic matter, and higher trophic levels (Pomeroy, 1974; Weber and Legge, 2011). Thus, it is implied that high HPC abundances may also be reflective of high nutrient availability discharged to the receiving environment. This is particularly important when considering the effects of this nutrient loading on receiving water bodies which may enhance conditions leading to eutrophication.

The microbial community, including heterotrophic bacteria, associated with NMB and UF technologies has not previously been characterized to the degree of detail that has been performed for more conventional wastewater treatment technologies (e.g. MBR, biological filtration, mechanical filtration). In fact, to our knowledge, no published studies exist concerning microbiological characterization data in NMB and UF treated aquaculture water. Results from this study indicate that the NMB employed in RAS-A generally maintained a stable composition of cultureable heterotrophic bacteria within different system compartments, showing minimal variability between sampling dates (Figure 4.1). Biofilm samples obtained from the NMB consistently demonstrated the highest cultureable abundances when compared to influent and effluent samples. While no cultivation data is available specifically concerning

this particular NMB technology, several studies exist regarding membrane bioreactors (MBR), which may serve as a basis for comparative evaluation. In previous investigations, Michaud *et al.* (2006) demonstrated that the biological reactor is a central contributing source of heterotrophic bacteria in a RAS, whereby biodegradable organic carbon trapped within the biofilm matrix in the reactor supports prominent growth of the heterotrophic community. In fact, as a consequence of their nutritional requirements and rapid growth rate, heterotrophic bacteria will frequently dominate the outer layers of the biofilm matrix within a bioreactor, effectively outcompeting the slower growing autotrophic bacteria that typically colonize the deeper layers (Zhu and Chen, 2002). This competition may significantly influence the functioning of a treatment technology, and is thought to be directly linked to the rate of organic carbon available for the heterotrophic fraction (Michaud *et al.*, 2006).

Overall, the NMB achieved, on average, one to two log reductions in HPC loads from influent to effluent samples, such that concentrations of 10^5 to 10^7 CFU/mL were persisting in effluent waters. This finding may be important when considering that, in the aquatic environment, heterotrophic bacteria have been implicated in the consumption of oxygen (Leonard *et al.*, 2002), production of metabolic by-products, and competition with slower growing autotrophic bacteria (Michaud *et al.*, 2006). A reduction in the nitrifying (autotrophic) population as a result of heterotrophic succession may result in elevated levels of chemical elements such as ammonia and nitrite, which is highly undesired in the rearing environment (Blancheton *et al.*, 2013). Moreover, it is proposed that the persistence could be ascribed to a releasing of bacteria from within the NMB, due to hydraulic shearing forces or an over-colonization of the nano-membrane substrate media. For example, in the case of a moving bed biological filter, Rusten *et al.* (2006) indicated that effects of hydrological flow over the filter

media induced shock and friction to the biofilm, resulting in a thinning and detachment of biofilm portions. Leonard *et al.* (2002) have previously demonstrated the correlation between total heterotrophic concentration attached to bioreactor media and free-living bacteria sheared from the membrane, which further supports these findings. However, it should be considered that the NMB technology employed in this study is highly novel, and operates in a distinctive manner compared to conventional wastewater treatment technologies. Thus, in the context of this study, it is proposed that the NMB positively impacted the heterotrophic community through the mass transfer of nutrients (e.g. organic and inorganic) and oxygen to the growing biofilm, which may account for the relatively high concentrations of cultureable heterotrophic bacteria.

One of the central problems in a RAS is the accumulation of suspended solids (both fine and colloidal) generated from feces, unmetabolized fish feed and biofloc material (including live and dead bacterial mass) (Cripps and Bergheim, 2000; Guitierrez-Wing and Malone, 2006). The buildup of large volumes of these materials within system waters is highly undesired, and can significantly affect microbial concentrations as a result of substrate availability (Blancheton *et al.*, 2013). The use of membrane filtration technology for enhanced separation and removal of the aforementioned constituents from rearing waters was investigated with regard to the cultureable heterotrophic fraction within the pilot-scale recirculating system supporting the UF technology. Results of microbiological cultivation experiments determined that bacterial populations were not homogeneously distributed throughout the system compartments. Specifically, the cultureable heterotrophic fraction displayed a highly variable trend, ranging from undetectable levels to 10^8 CFU/mL across system compartments (Figure 4.2). Cultivation results of heterotrophic bacteria enumerated

from source water was comparable with results from RAS-A influent samples, such that HPC abundances of 10^6 to 10^7 CFU/mL were detected within each of pilot-scale systems. This cultureable reproducibility among source water HPCs in RAS-A and RAS-B supports the comparison of the pilot-scale systems based on cultivation data.

Following exposure to the UF, enumeration results indicate that the UF achieved, on average, over a five log reduction of cultureable heterotrophic bacteria, resulting in complete log removal to undetectable levels. The results from this study were consistent with reports from other studies regarding the evaluation of bacterial removal efficiency of membrane filters when treating various types of wastewater. For instance, a study by Glucina *et al.* (2000) demonstrated the capability of a membrane filter (0.01 μm pore size) to achieve over four log reductions of heterotrophic bacteria from surface waters. Moreover, membrane filtered systems (0.005 and 0.01 μm pore size) in studies by Guo *et al.* (2009) and Nakatsuka *et al.* (1996) achieved over two and three log reductions of total bacteria from surface waters, respectively. In light of the supporting reports regarding bacterial removal efficiencies, it is suggested that the UF employed in the RAS was able to effectively remove a large fraction of the heterotrophic microbial community from rearing waters via mechanical separation, achieving high bacterial removal efficiencies when used to continuously treat rearing waters. Following backwashing events of the UF membrane core, higher loads of HPCs were detected, and while this data is important, it is not unexpected considering the aforementioned removal efficiency.

In an effort to investigate the spatial distribution of the heterotrophic microbial community and the implications for persistence in ecological niches within the system following treatment, RAS-B biofilm tank samples containing suspended substrata were

collected and enumerated. Results indicated a four log increase in HPC loads compared to the undetectable concentrations found at the outlet of the UF. This persistence may be demonstrative of the ability of the heterotrophic community to successfully maintain physiological status and competition for minimal resources within the treated effluent waters in the biofilm tank. As previously discussed, the majority of bacteria in aquatic environments readily organize into complex biofilms that form at water-surface interfaces (Wietz *et al.*, 2009). Therefore, the concept of community support within a biofilm matrix is implicated as a probable mechanism for bacterial persistence in unfavourable conditions (e.g. low nutrient availability as a result of wastewater treatment).

5.1.2 Consideration of the Presence of Classical Fecal Indicator Bacteria *E. coli* and *Enterococcus* spp., and fish Pathogens *Yersinia* spp. and *Aeromonas* spp.

The use of selective and differential media in this study allowed for the enumeration of specific pathogens within the collected environmental water samples from the various aquaculture systems. In this study, cultureable *E. coli*, *Enterococcus* spp., and pathogenic bacteria from the genera *Yersinia* and *Aeromonas* were enumerated to assess the presence and spatial distribution of fecal indicator bacteria and pathogens within the overall community.

Results of the media-based enumeration of FIB and pathogens of interest highlighted an interesting trend. Overall, the relative abundance of cultureable *Yersinia* spp. and *Aeromonas* spp. in all studied systems were consistently higher than *E. coli* and enterococci by at least two orders of magnitude. In fact, detectable loads of FIB in FTS-A that fell within the statistically relevant range were then only observed on a single sampling event during August, and were only found within the treatment pond location. Additionally, cultureable abundances of FIB detected within the FTS-B were found in all sampled locations, with the exception of

the influent well water (Figure 3.2). With regard to the recirculating systems, *E. coli* and *Enterococcus* spp. were not detected at statistically relevant levels within either of the pilot-scale systems, indicating rearing water quality was likely in optimal status. These findings can be compared to a study conducted by McAdams *et al.* (1996), in which cultureable loads of fecal indicator bacteria (FIB) were undetected within rearing water samples by traditional plating techniques.

Owing to the fact that fishes are ectothermic and poikilothermic (*i.e.* source of body temperature is external, and that body temperature reflects ambient conditions), evidence of fecal contamination in aquaculture waters indicates introduction of these indicator organisms from an external origin (e.g. feed and source water) (Del Rio-Rodriguez *et al.*, 1997). The flow-through systems under consideration are situated in rural areas and are densely populated with a variety of local waterfowl and wildlife in the regions of the fishing pond and treatment ponds. Other researchers have suggested the presence of these animals may adversely affect the bacteriological quality of small water bodies (Abulreesh *et al.*, 2004). Ashbolt *et al.* (2001) found higher incidences of fecal contamination in ponds with waterfowl (e.g. geese and ducks) as opposed to those without. Additionally, the high values of HPC concentrations in both flow-through systems reported previously may also reflect a general nutrient enrichment by waterfowl. Historically, the detection of these indicator organisms have also been used as an alternative to that of pathogens (Halliday and Gast, 2011). Compared to the latter, they are able to rapidly signify microbial contamination using easily applicable methods, such as plate-count enumeration. In any case, the use of fecal indicators provides the probability, not the certainty, of the presence of pathogens. The results of this study, in combination with epidemiological data in literature (Halliday and Gast, 2011; Luo *et al.* 2011), therefore, may challenge the

reliability of the currently used fecal indicator bacteria as accurate representatives of the presence of pathogens. However, it is important to note that the relative abundance of these FIB may be underrepresented in this study due to the inherent cultivation bias associated with the traditional microbiological enumeration method. In fact, a number of microbial species, including *E. coli* and *Enterococcus* spp., have demonstrated the stress-induced ability to transition into a viable but non-cultureable (VBNC) state in order to combat unfavourable environmental conditions (Oliver, 2005; Ferguson and Signoreto, 2011). Cells entering the VBNC state often exhibit a decrease in size (dwarfing), and are characterized by lowered metabolic activity (including reductions in nutrient transport) while preserving cellular integrity and pathogenic traits, such that revival into a cultureable state can occur when suitable environmental conditions are restored (Oliver, 2005). There is a great deal of evidence suggesting that upon the release of these enteric bacteria from their primary hosts, the majority will expire as a result of harsh biotic and abiotic environmental conditions (Ferguson and Signoreto, 2011). In the context of the outdoor flow-through systems, it is suggested that the low abundances, or non-detection of FIB during colder climate months (e.g. February and November 2013 and April 2014) may be a result of unfavourable environmental conditions triggering a stress-induced transition to the VBNC state. Moreover, Verschuere *et al.* (2000) acknowledged that microbial populations, including the heterotrophic community, might be implicated in the maintenance of a stable rearing environment through either the release of chemical substrates that have a bactericidal or bacteriostatic effect on other microorganisms (*i.e.* FIB), or as a result of competition for nutrients.

Consistent with previously mentioned cultivation results, high levels of *Yersinia* spp. and *Aeromonas* spp. were most frequently detected within the treatment pond location of the

Northern flow-through system across all seasonal sampling events, indicating accumulation within pond waters following passage through the rearing environment. Across all samples collected from this system, the relative abundance of *Yersinia* spp. was typically higher than *Aeromonas* spp. by four orders of magnitude or greater (Figure 3.4) regardless of seasonal sampling event. In comparison, cultivation data for the local flow-through system revealed a similar trend, whereby the relative abundance of *Yersinia* spp. was generally higher than *Aeromonas* spp. (Figure 3.5), and most frequently found in the on-site pond and discharge effluent within the system. Unique to this system, however, was a generally decreasing trend in *Aeromonas* spp. concentrations throughout the progression of the system compartments, such that following passage through the system, loads were reduced by two to three orders of magnitude. Therefore, between the two flow-through systems, the local flow-through system showed an increased removal efficiency of *Aeromonas* spp. compared to the Northern. While not explicitly measured in this study, the degree of stagnation has been implicated in the growth and accumulation of *Aeromonas* spp. in biofilms within aquatic environments (Bomo *et al.*, 2004). In flowing environments, microbial adhesion and biofilm formation is facilitated by factors such as whole cell hydrophobicity, autoaggregation, cell surface structures and cell surface charges (Stenstrom, 1989; Bomo *et al.*, 2003; Rickard *et al.*, 2004). In general, it can be implied that enhanced bacterial adhesiveness is directly correlated to cell hydrophobicity, and vice versa. Bomo *et al.* (2003) investigated the relative hydrophobicity of various bacterial strains and found that aeromonads possessed a higher cell surface hydrophobicity than *Yersinia ruckeri*. Personal communication with the Northern site operations personnel indicated a daily water volume use of 1.8 to 1.9 million litres, which may have contributed to lower hydraulic retention times in the treatment ponds (Facility management personnel,

personal communication, 2013). Presumably, higher retention times in the local system compared to the Northern system may have promoted the recruitment of *Aeromonas* spp. into growing biofilms, although explicit retention times for each system are unknown. However, it is suggested that factors such as increased hydrophobicity along with prevailing water flow conditions may explain the enhanced removal efficiency observed in the local system.

Conversely, detectable concentrations of cultureable *Yersinia* spp. and *Aeromonas* spp. in well water samples from the Northern and local systems were below the statistically relevant range among all seasonal events. These samples were considered as pseudo-background environmental values, as they had been sampled prior to contact with surface system waters. In light of this, the absence of detectable pathogens likely suggests that influent well water may not have been a prominent contributing factor for pathogen introduction to the system. Rather, the following are proposed as possible parameters contributing to the introduction of pathogens into these systems.

Several species of *Aeromonas* and *Yersinia*, including *Aeromonas hydrophila* and *Yersinia enterocolitica*, have been reported to occur ubiquitously and autochthonously in aquatic environments (Waage *et al.*, 1999). It should, therefore, be considered that the low cultivability of these organisms may not be reflective of a real absence of the pathogens, but rather absence due to cultivation bias. Certain species of *Yersinia*, such as *Yersinia enterocolitica* and *Yersinia pseudotuberculosis*, have been identified as heterogeneous bacterial species with a wide range of animal hosts that serve as reservoirs (Fredriksson and Korkeala, 2003). As previously indicated, the flow-through systems under consideration are heavily populated with wild animals, which may contribute to the transmission of the pathogen to source water. This is supported by Fredriksson and Korkeala (2003) who reported the

transmission of *Y. pseudotuberculosis* to environmental water sources by animal vectors such as rabbits and birds.

Aquaculture systems with a recirculating design may favour the proliferation of pathogenic organisms and the spread of disease as a result of the closed-system flow of rearing water. A number of factors may contribute to this tendency, including the buildup of biofilms and suspended solids in rearing tanks, the decreased turnover of rearing water, and the treatment approaches (including technologies) in the system (Blancheton *et al.*, 2013). Pathogens belonging to the genera *Yersinia* and *Aeromonas* were detected in each of the pilot-scale systems using cultivation techniques. Although these pathogens have long been associated with significant instances of disease and mortalities in fish rearing, the ecology and biology of these bacterial genera have been poorly studied in relation to recirculating aquaculture systems. Consequently, limited information is available concerning the enumeration, distribution, and potential for their persistence in recirculating aquaculture systems, particularly with regard to the treatment technologies under consideration. Resultantly, the data from this study provide further knowledge toward the understanding of pathogen occurrence in recirculating systems, and implications for removal with regard to the respective wastewater treatment approaches.

A comparison of the pathogen cultivation data in RAS-A influent water with that of RAS-B indicated that abundances of *Yersinia* spp. and *Aeromonas* spp. in each system were analogous across the monitoring period, which supports comparative assessment of treatment technologies. Specifically, initial reference levels of *Yersinia* spp. from influent water samples in both systems were in the order of 10^5 to 10^6 CFU/100 mL, while concentrations of *Aeromonas* spp. reached 10^4 CFU/100 mL (Figure 4.3; Figure 4.4). In each of the pilot-scale

systems, *Yersinia* spp. abundances were greater than *Aeromonas* spp., which is consistent with results from the two flow-through systems. Overall, this suggests that, regardless of system design (e.g. open or closed), *Yersinia* spp. appears to be a more prevalent pathogen in the rearing environment compared to *Aeromonas* spp. This may be related to parameters common among all systems, such as reared fish species. Interestingly, the reared fish populations varied among the systems, with the recirculating system rearing Atlantic salmon (*Salmo salar*) while the flow-through systems supported production of Rainbow trout (*Oncorhynchus mykiss*). Literature indicates that species of *Yersinia* spp. and *Aeromonas* spp. have been directly correlated with trout and salmon rearing practices (Schmidt *et al.*, 2000). Therefore, further investigation into the common parameters among sites is necessary in order to determine the most likely route of introduction into the rearing systems.

In the NMB treated system, highest pathogen loads were contained within the biofilm sample obtained from the internal compartment of the NMB, approximately one to two orders of magnitude greater than planktonic samples (Figure 4.3). Notably, persistence in effluent samples was evident for both *Yersinia* spp. and *Aeromonas* spp., which may give rise to the dissemination of these pathogens back into rearing waters. Coquet *et al.* (2002a) and Gavin *et al.* (2003) have previously shown that aquatic pathogens such as *Yersinia* spp. and *Aeromonas* spp. readily form large biofilm structures in aquatic environments, primarily as a mechanism for survival outside of a fish host. In a study by Baleboan *et al.* (2001) regarding the biofilm formation of *Yersinia* spp., it was reported that 10^4 CFU/100 mL of free bacteria were released from the biofilm into the rearing waters, which corresponds with the results from this study. Given that the recirculating aquaculture environment provides many water-surface interfaces for colonization, and that the NMB in consideration is designed to promote the establishment

and growth of biofilms, the results from this study are not unexpected, and further support the hypothesis that aquatic pathogens present within rearing waters may be frequently found within the biofilm matrix. Moreover, when considering the results from this study in concert with available literature, it is suggested that biofilm formation for the pathogens *Yersinia* spp. and *Aeromonas* spp. may well be an adaptive advantage for survival in the fluctuating conditions that prevail in the aquatic environment.

The occurrence of pathogen presence and persistence in treated effluent waters could be ascribed to the release of pathogens from the NMB that were able to maintain physiological status, allowing for colonization in the biofilm tank following treatment. These results again support the proposed notion by Leonard *et al.* (2002) that the bioreactor functions as a nutrient-rich environment, supporting the proliferation of microorganisms likely by improvement of bacterial physiological status within the microenvironment of an established biofilm.

Culture-based results for the UF treated system (RAS-B) revealed similar cultivation results compared to the NMB treated system (RAS-A), although a significant difference in log removal was evident between the different treatment technologies. As previously indicated, source water samples in the RAS-B were analogous to those in RAS-A. Following passage through a pre-filter ($\leq 500 \mu\text{m}$), pathogen loads remained consistent with values from planktonic source water concentrations, indicating persistence within the system prior to membrane filtration (Figure 4.4). This was not unexpected, as the pore size of the pre-filter permits passage of any material (including microorganisms) smaller than the respective pore diameter. Analogous to HPC results, the UF achieved, on average, up to seven log reductions in cultureable pathogen loads following exposure, resulting in non-detectable pathogen loads.

In particular, *Yersinia* spp. loads were reduced by approximately six orders of magnitude, and *Aeromonas* spp. loads were reduced by three orders of magnitude from source water samples to ultra-filter outlet. While membrane filtration has, to our knowledge, not previously been evaluated explicitly as a pathogen removal treatment in aquaculture systems, its ability to remove fine and colloidal material (and other waste products) from wastewater has been reported (Sharrer *et al.*, 2007). For example, a membrane filtration treated system (0.05 µm pore size) in a study by Gomez *et al.* (2007) achieved approximately 91 and 99% removal of suspended solids and turbidity, respectively, from municipal wastewater. Moreover, investigations by Nakatsuka *et al.* (1996) and Castaing *et al.* (2010) demonstrated the capability of membrane filtration to remove high levels of organic carbon, suspended solids, and fine particulate matter from wastewater. When considering the above-mentioned literature reports concerning suspended solids removal efficiencies, it is suggested that the use of the UF employed in this study may have positively impacted rearing conditions (*i.e.* improvement of rearing water quality) in the system through the direct removal of available nutrients and physical separation of pathogens from the rearing environment, although specific removal efficiencies of suspended solids (and waste material) were not obtained for this study.

Overall, a comparison of the removal efficiencies of the treatment technologies suggested that the UF demonstrated the potential to remove greater abundances of bacterial pathogens from the rearing waters of a pilot-scale system when compared to the NMB. However, it should be noted that the abundances of viable pathogens in the effluent samples from each of the pilot-scale systems (*i.e.* effluent and biofilm tank) were markedly similar, such that concentrations of bacterial pathogens being re-circulated to the rearing tanks were of the same orders of magnitude (10^2 CFU/100 mL for *Aeromonas* spp. and 10^3 to 10^4 CFU/ 100

mL for *Yersinia* spp.). This may suggest that the NMB and UF technology may both be effective for water treatment and pathogen removal in recirculating aquaculture systems. However, more research is needed to determine the economical and operational efficacy of using these treatment approaches in a full-scale RAS before they can confidently be used as a pathogen control treatment in a field-scale (or commercial) rearing system.

The use of a conventional cultivation approach was undertaken with the aim of establishing a culture collection of *Yersinia* spp. and *Aeromonas* spp. pathogen isolates for functional analyses (e.g. such as determination of antibiotic resistance profiles for FTS-B isolates). However, when considering the intrinsic biases of culture-dependent isolation, the results of these enumerations are thus only indicative, and should be further substantiated in future studies with the use of more specific molecular-based quantitative methods, such as qPCR. This is particularly important for the detection of pathogens from the environment able to persist in a viable but noncultureable (VBNC) state, which could not otherwise be as explicitly quantified using the cultivation method.

5.1.2.1 Genotypic Confirmation of Yersinia spp. and Aeromonas spp.

Even under optimal environmental conditions within an aquaculture rearing system, healthy fish lacking any clinical signs of disease may harbor opportunistic pathogenic microorganisms, such as those from the genus *Yersinia* and *Aeromonas*, that impose serious risks for the spread of contagious disease, not only within the aquaculture system but also within the greater population. Generally, a disease state becomes evident during stressful environmental conditions, and the severity of disease is influenced by a number of interrelated factors, including bacterial virulence, the degree of stress exerted on the fish population, the physiological condition of the host, and the degree of genetic resistance inherent within the

fish population (Bottone, 1999). Moreover, factors such as poor rearing water quality and overcrowding of fish can impose stress, resulting in immunosuppression and an increased susceptibility to infection by both strict and opportunistic pathogens (Bullock *et al.*, 1997). Considering the financial and ecological implications of disease outbreak in an intensive aquaculture system, the monitoring and definitive identification of specific pathogens isolated from rearing waters is fundamental for the optimal management and disease-control practices in a system.

In this study, the use of qualitative PCR permitted molecular-based confirmation of select pathogenic species of interest isolated from both the recirculating and flow-through aquaculture systems under investigation. Cultureable organisms were first identified as presumptive isolates, which then underwent genotypic screening for further characterization and confirmation.

To characterize presumptive *Yersinia* spp. isolates, two synthetic species-specific oligonucleotide primer pairs were used in order to distinguish between *Y. enterocolitica* and *Y. ruckeri*. The first primer pair, Y1-Y2, was used to amplify a 330-bp fragment of the 16S rRNA gene exclusively of the *Y. enterocolitica* species, whereas the second primer pair (YER8-YER10) amplified a 575-bp fragment from unconserved regions of the *Y. ruckeri* 16S rRNA gene sequence. Similarly, the genus-specific primer pair (gyrB3-gyrB14) was used to characterize presumptive isolates of the genus *Aeromonas*.

Qualitative PCR results revealed relatively high confirmation percentages for *Aeromonas* spp. from all sample sites (Table 4.3; Table 3.3), which supports the media-based data identifying *Aeromonas* spp. as a constituent within the microbial communities in various aquaculture systems. Moreover, the recirculating systems under consideration appeared to

exhibit slightly higher confirmation results compared to the flow-through systems, although this difference was marginal. Overall, this suggests that the isolation medium selected in this study was reliable in distinguishing *Aeromonas* species from other genera that inhabit the aquatic environment in aquaculture systems. Specifically, cultivation of *Aeromonas* spp. was carried out using the selective media Ampicillin Dextrin Agar (ADA). Originally developed in 1987, several studies have reported its effectiveness as a highly suitable media for the isolation and recovery of *Aeromonas* spp. (Havelaar *et al.* 1987; Handfield *et al.*, 1996). ADA employs a detergent, deoxycholate, and an antibiotic, ampicillin, as selective agents for recovery, as studies indicate the majority of aeromonads are intrinsically resistant to these components (Handfield *et al.*, 1996). Additionally, ADA relies on the high specificity of dextrin fermentation for the detection of aeromonads. All members of the genus *Aeromonas* ferment dextrin, resulting in the production of acid by-products and presence of yellow colonies on the media. The growth of non-dextrin fermenting bacteria is indicated by the presence of green or colorless colonies on ADA. As such, there is potential for phenotypic misidentification, which may explain the lack of absolute molecular confirmation for all presumptive isolates. Overall, the confirmation data suggests that *Aeromonas* spp. is indeed present within the microbial population in each of the respective recirculating and flow-through aquaculture systems, which warrants a discussion of its significance.

Aeromonas species are recognized as causative agents of a wide spectrum of diseases in both humans and animals (Ghenghesh *et al.* 2008). Previous studies have revealed that several motile *Aeromonas* species are becoming food and waterborne pathogens (both strict and opportunistic) of increasing importance (Araújo *et al.*, 2002; Ansari *et al.*, 2011). Members of this genus have been long associated with several food-borne outbreaks, and have

more recently become more frequently isolated from patients with traveler's diarrhea (von Graevenitz, 2007). In particular, *Aeromonas salmonicida* and *Aeromonas hydrophila* have been documented as the causative agents of furunculosis, ulcerative disease, hemorrhagic disease, red sore disease, and septicemia in fish (Austin, 2009). Currently, as a putatively emerging enteric pathogen, *Aeromonas* species have demonstrated the inherent capability to grow in water distribution systems, especially in biofilms, where they may be resistant to disinfection and removal (Chauret *et al.*, 2001). For these reasons, further investigation of the presence and pathogenicity should be conducted regarding this genus in aquaculture systems. This is especially important with regard to the possibility for transmission to humans (via ingestion of contaminated product), as well as to the receiving environment (in the case of the flow-through systems).

Molecular-based identification of *Yersinia* isolates, namely, *Y. enterocolitica* and *Y. ruckeri*, revealed lower percent confirmation results compared to those for *Aeromonas* spp., as depicted in (Table 3.2; Table 3.3; Table 4.3; Table 4.4). Overall, the presence of *Y. enterocolitica* was observed to be the prevailing species in the community isolates, compared to *Y. ruckeri*. In an effort to understand the discrepancy between the cultivation results of presumptive isolates and the genotypic confirmation data, as well as the significance of *Yersinia* spp. in the aquaculture systems, it is important to consider the taxonomic and phenotypic information in literature concerning members of the genus *Yersinia*. Among the species designated for qualitative PCR testing, *Y. enterocolitica* was selected due to its significance as an enteric bacterium that has been identified as a potential waterborne human pathogen (Theron *et al.*, 2002; Sharma *et al.*, 2003). Surveillance data indicate a global distribution of the pathogen, accompanied by an extensive increase in the number of non-

outbreak-related isolates and cases of yersiniosis reported during the last two decades (Wannet *et al.*, 2001). Given that *Y. enterocolitica* is associated with animal hosts (such as fish) and shed in the feces of infected animals, it is reasonable to assume that waterborne transmission of *Y. enterocolitica* may be occurring, similar to other agriculturally important microbial pathogens.

Of additional importance are the *Yersinia* species *Y. pseudotuberculosis* and *Y. pestis*, which have historically been known to cause human disease (Bottone, 1999). Overall, while most attention in literature has focused on these three species, several other, less familiar *Yersinia* species have been documented to exist. These remaining eight species, identified as *Y. aldovae*, *Y. bercovieri*, *Y. frederiksenii*, *Y. kristensenii*, *Y. intermedia*, *Y. mollaretii*, *Y. rohdei*, and *Y. ruckeri*, have not been as comprehensively studied. Due to the absence of classical *Yersinia* virulence markers, these species are generally considered to be environmental and non-pathogenic species, and have been successfully isolated from freshwater (Massa *et al.*, 1988), sewage (Ruhle *et al.*, 1990), and drinking water (Kuznetsov and Timchenko, 1998).

The results from this study, including the occurrence of variation between cultivation and genotypic characterization, suggest a more discriminate approach to analysis should be considered for future investigations. Specifically, this can incorporate the inclusion of additional *Yersinia* species, as only two out of the eleven known species were selected for confirmation assessment. *Yersinia* Selective Agar (YSA) was selected as the differential selective media for the isolation and enumeration of *Yersinia enterocolitica*. Nonetheless, Bockemühl and Wong (2003) have documented its applicability for the isolation of *Yersinia* species other than *Y. enterocolitica*, including *Y. pseudotuberculosis*, *Y. intermedia*, and *Y. frederiksenii*. Consequently, it is possible that species other than *Y. enterocolitica* were

selected for on YSA, which may account for the observed genotypic results. Due to the absence of previously designed genus-specific primers for *Yersinia* spp., it was not possible to confirm all presumptive *Yersinia* spp. isolates using a genotypic approach.

In other studies concerning the investigation of environmental *Yersinia* spp. isolates, the prevalence of *Y. enterocolitica* and *Y. ruckeri* were found to be markedly lower compared with confirmation data from this study. For instance, Sulkavelidze *et al.* (1996) reported that only 1% (14) of 1,295 presumptive environmental isolates were confirmed as *Y. enterocolitica*, or *Y. enterocolitica*-like species. This likely suggests that the environment of the aquaculture rearing waters supports a larger population of *Yersinia* spp. compared to environmental samples. Additionally, the higher prevalence may be implicated in an increased likelihood of a *Y. enterocolitica*-associated disease outbreak in the respective system. Previous studies have demonstrated that the incidence of *Y. ruckeri* related enteric redmouth (ERM) outbreaks in freshwater fish farms is correlated with seasonality and temperature (Rodgers, 1992; Romalde *et al.*, 1994). Specifically, Rodgers (1992) indicated that the majority of ERM outbreaks occurred at water temperatures of 11 to 18°C. Interestingly, the highest confirmation data for *Y. ruckeri* in this study was found within the FTS-B location in which sampling events were restricted to summer months. Comparatively, the other systems demonstrated lower results, ranging between 1-3% confirmations. Therefore, it is tempting to speculate that the seasonal effects experienced in the FTS-A, and the temperature conditions within RAS-A and RAS-B may have been too low to support the growth and persistence of *Y. ruckeri*. However, the lack of continuous temperature specific data confounds our ability to fully validate this hypothesis.

Future studies may focus more diligently on the effects of temperature in these aquaculture systems in concert with epidemiological tracking of diseases caused by *Yersinia*

spp., such as ERM. Furthermore, as previously mentioned, continuing studies concerning the presence and pathogenicity of *Yersinia* spp. within aquaculture systems is recommended, with particular focus on the transmission of disease to humans and animals, and implications for dissemination to receiving environments. This knowledge is required for the development of more efficient approaches to the protection of animal, human, and environmental health.

5.1.2.2 Frequency and Distribution of Antibiotic Resistance among Waterborne Yersinia spp. and Aeromonas spp. isolates from a Local Flow-Through System

In this study, ABR levels in waterborne *Aeromonas* spp. and *Yersinia* spp. isolated from the local flow-through aquaculture system were measured and characterized. Pathogen isolation from this site provided a unique opportunity to investigate the incidences and patterns of antibiotic resistance in *Yersinia* spp. and *Aeromonas* spp. that had been exposed to prophylactic and therapeutic treatment with antibiotics as part of facility operations. Due to this knowledge that the aquaculture system under consideration routinely administered antibiotic treatment, and the widely recognized capability of aquatic bacteria to develop resistance as a result of antibiotic exposure, it was anticipated that high instances of ABR would be observed in pathogens isolated from the impacted aquatic environment.

Antibiotic profiling results revealed that approximately 65.5% (38/58) of total *Aeromonas* spp. and 63% (63/100) of total *Yersinia* spp. cultivated from sampling locations in the FTS-B demonstrated phenotypic resistance to three or more of the tested antibiotics (termed multidrug resistance; MDR) (Table 3.2). These findings are supported by resistance patterns reported by Schmidt *et al.* (2000), whereby water samples from two freshwater Danish fish farms were found to harbor aeromonads demonstrating high percentages of MDR. Interestingly, these same authors did not detect antibiotic resistance among *Y. ruckeri* isolates

from the same sites, although increased resistance have been reported from other geographical areas where enteric redmouth disease caused by *Y. ruckeri* is enzootic (Klein *et al.*, 1996).

This trend was reinforced by the rate and spatial variation of MDR frequencies observed in *Aeromonas* spp. isolated from different regions of the FTS-B. For instance, an increasing trend for MDR frequency was observed with respect to water flow, such that highest levels were located within discharge effluent samples during both the initial (June 2013) and secondary (May 2014) events. *Aeromonas* spp. isolates cultivated during the initial sampling event in June (2013) demonstrated a 33.3% (3/9) MDR frequency in the pond supplying influent water, compared to 83.3% (5/6) MDR frequency observed for *Aeromonas* spp. within discharge effluent. Similarly, *Aeromonas* spp. isolates cultivated from early rearing water displayed a 31.0% greater MDR frequency than the isolates within the pond samples. Results regarding MDR frequencies for the secondary sampling event in May (2014) reflected a comparable pattern, whereby increased rates of MDR were demonstrated throughout the course of the system. Pond water samples demonstrated a 6.7% increase from the initial sampling event, while early rear and discharge effluent MDR frequencies increased to 70.0% and 86.6%, respectively. Comparatively, ABR results for *Yersinia* spp. revealed a comparable increasing trend in MDR frequency throughout the system locations. Discharge effluent locations contained the highest prevalence of MDR isolates, and were generally 40% higher compared to influent pond water (Table 4.2).

The use of antibiotic therapy in aquaculture practices has been reported to coincide with the increased frequency of antibiotic resistant bacteria (DePaola *et al.*, 1995). Miranda and Zemelman (2002) investigated the prevalence of antibiotic resistant aeromonads in freshwater salmon farms and indicated that the significantly highest proportions of resistant

isolates were found in effluent samples. These studies, along with the results from this study, suggest that the prevalence of MDR bacteria increases as a result of antibiotic treatment to rearing waters, whereby susceptible microorganisms are inhibited, allowing for colonization by resistant bacteria. Overall, the occurrence of higher MDR resistance in the discharge effluent location indicates that prevailing factors in the system may have promoted the development or transfer of resistance to *Yersinia* spp. and *Aeromonas* spp. It is proposed that the causative factors may be selective pressure from antibiotic agents, a favourable environment for gene transfers in the form of biofilms, or as a result of high organic loading in the system. While this has yet to be explicitly clarified, the results of this study do show a simple correlation between the use of antibiotics and MDR levels.

Resistance profiles of Waterborne Yersinia spp.

As depicted in Figure 3.6A, the prevalence of antibiotic resistance (%) among *Yersinia* spp. isolates varied among antibiotic classes tested. Overall, *Yersinia* spp. isolates from both the June 2013 and May 2014 sampling events displayed complete resistance to the antibiotics AMC, E, and OTC, which belong to the β -lactam, macrolide, and tetracycline classes, respectively (Table A1). High resistance levels were also demonstrated for VA, CRO, C, AM, and CTX. These findings are in general agreement with those of previous investigations of the susceptibilities of *Y. enterocolitica* to β -lactam antibiotics conducted in various countries (Lyons *et al.* 1991; Pham *et al.*, 1991; Hornstein *et al.* 1985). Notably, the ability of *Y. enterocolitica* to demonstrate resistance to penicillins and cephalosporins has been widely documented (Tzelepi *et al.* 1999; Bottone 1999), and is governed in part by the production of two chromosomally encoded β -lactamases (A and B). Individually, they are able to

demonstrate activity against a variety of penicillins and (Cornelis and Abraham, 1975), and have also been found to act synergistically to confer resistance to a variety of other β -lactam antibiotics (Lyons *et al.*, 1991). Several reports document the characteristic expression of these β -lactamases in several species of *Yersinia* spp., such as *Y. intermedia*, *Y. enterocolitica* and *Y. frederiksenii* (Falcao *et al.*, 2004; Stock and Wiedemann, 2003; Tzelepi *et al.*, 1999). Therefore, the occurrence of high levels of resistance to amoxicillin, ampicillin, ceftriaxone and cefotaxime (third generation cephalosporins) among tested *Yersinia* spp. isolates in this study may reflect an increase in resistance to these drugs due to plasmid-mediated expression of β -lactamases. However, since the genotypic identities of all *Yersinia* spp. isolates in this study were unable to be confirmed, further studies are necessary to confirm this hypothesis.

Additionally, the different susceptibilities observed in this study to the tested β -lactam antibiotics may be suggestive of complex regulation and expression of β -lactamases in the isolated species of *Yersinia*. The complete lack of susceptibility to erythromycin by *Yersinia* isolates is in agreement with previous investigations by Hornstein *et al.* (1985), Kwaga *et al.* (1990) and Bonardi *et al.* (2010). In fact, the flow-through system under consideration communicated erythromycin had previously been administered to rearing waters for both prophylactic and therapeutic treatment, without success (site management personnel, personal communication, 2014), which supports the results of this study. Alternatively, *Y. enterocolitica* may be intrinsically non-susceptible to this macrolide antibiotic. Lyons *et al.* (1991) reported findings of total resistance to tetracycline and high levels of resistance to chloramphenicol among *Y. enterocolitica*, which is analogous to our results. Comparatively, the *Yersinia* spp. isolates tested were found to be most susceptible to sulfamethoxazole-trimethoprim and ciprofloxacin, which is widely supported by published studies (Stock and Wiedemann 1999,

2003; Tzelepi *et al.* 1999; Falcao *et al.*, 2004). This finding is also clinically relevant, as these antibiotics are routinely employed for the treatment of urinary tract infections in humans (CDC, 2013).

Resistance Profiles of Waterborne Aeromonas spp.

Similar to the trend observed for *Yersinia* spp., all isolates obtained from both June (2013) and May (2014) events demonstrated complete phenotypic resistance to the antibiotics erythromycin, oxytetracycline, and ampicillin (Figure 3.6B). Generally, high occurrences of resistance were also exhibited for the antibiotics D, VA, SXT, AMC, and S. The high resistance observed against oxytetracycline and SXT is supported by findings from a study by Petersen *et al.* (2002), in which all *Aeromonas* strains were resistant to the commonly used antibiotics tetracycline and trimethoprim. Similar resistance patterns were reported by DePaola *et al.* (1995) and Kirkan *et al.* (2000), who documented high levels of antibiotic resistance to erythromycin, amoxicillin, and ampicillin in *Aeromonas* species isolated from a eutrophic lake and a European river, respectively. Additionally, Huys *et al.* (2002) found oxytetracycline-resistant strains of *Aeromonas* isolated from fish farms and hospital waste, although the proportions of OTC resistance found in this study are markedly higher. Through personal communication with facility personnel, it was determined that OTC had been historically used for both prophylactic and therapeutic treatment, but was discontinued due to persistence of fish mortalities (Management personnel, personal communication, 2014). Although OTC was no longer administered during the sampling period in this study, it is suggested that the high frequency of resistant aeromonads cultivated from the system, as well as the high resistance levels of the isolates may be a direct consequence of former use in the facility. For example,

sub-lethal concentrations may have persisted within the sediment of the pond and/or discharge effluent environment, creating a selective pressure following treatment.

It is also suggested that a high prevalence of resistant bacteria with tetracycline resistance determinants may be indigenous in this aquatic environment. Tetracyclines are among the most frequently administered antibiotic agents in veterinary medicine (Schmidt *et al.*, 2000). Members of the tetracycline family, oxytetracycline (OTC, first generation tetracycline) and doxycycline (D, second generation) function to inhibit microbial protein synthesis by preventing the attachment of aminoacyl-tRNA to the ribosomal acceptor (A) site (Chopra and Roberts, 2001); thereby capable of exhibiting activity against a wide range of Gram-positive and Gram-negative bacteria, including members of the genus *Aeromonas* and *Yersinia*. In this study, *Aeromonas* strains were fully susceptible to the effects of CIP, with no observed resistance. Additionally, results demonstrate the effectiveness of CTX and CRO with demonstrated susceptibility against *Aeromonas* strains isolated from the flow-through system, and are in agreement with Schmidt *et al.* (2000).

Overall, the use of a traditional culture-based screening approach successfully permitted for the establishment of a preliminary assessment of ABR in pathogens of interest within a local flow-through system (FTS-B). In accordance with widespread literature, the results from this study suggest that aquatic environments (such as open flow-through aquaculture systems) may be a significant reservoir of ABR pathogens of human and animal significance, such as those species belonging to the genera *Yersinia* and *Aeromonas*. Moreover, depending on the discharge strategy, these systems may be implicated in the dissemination of MDR resistant bacteria into the broader environment, which has concerning implications regarding human health. The pollution of receiving ecosystems with pathogens

exhibiting reduced susceptibilities to commonly used, clinically relevant antibiotics (such as third generation cephalosporins, tetracyclines and penicillins) has considerable consequences for public health, and thus, the importance of these findings is emphasized. This is also particularly important when considering the levels of MDR observed in the on-site pond water. Given that its main use is for public fishing activity, the implications of the handling and consumption of fish containing ABR bacteria should be further investigated.

Previous research in this area has demonstrated that the manifestation and dissemination of bacterial ABR is the result of countless, complex interactions between microorganisms, antibiotics, and the surrounding environment (Schmidt *et al.*, 2000). As such, a better comprehension of these interactions is necessary if research-based risk assessments concerning the use of antibiotics in animal production are to be made. Although programs like CFIA (Canadian Food Inspection Agency) exist to ensure seafood safety at the processing level, the enhancement of pathogen-based ABR surveillance programs will aid in defining the association of ABR levels in relevant human and food-producing animal pathogens, such as those found within aquaculture environments.

5.2 Microbial Community Integrity in Aquaculture Systems as Measured through Functional and Structural Profiling Techniques

The characterization of microbial communities within aquatic environments has become increasingly successful through the integrative combination of complementary culture-dependent and –independent microbiological methods (Kirk *et al.*, 2005; Weber and Legge, 2010). However, as previously stated, there is still evidence of a gap in the knowledge regarding microbial community dynamics in land-based aquaculture ecosystems, despite their increasing significance and popularity. A multiphasic approach that employed paired

methodology was undertaken in an effort to provide a more comprehensive view of how spatial and temporal variation impacts freshwater bacterial communities in flow-through aquaculture systems of varying design. In particular, denaturing gradient gel electrophoresis (DGGE) analysis generated a descriptive community DNA-based genetic ‘fingerprint’ of complex bacterial assemblages through the separation of PCR-amplified DNA fragments. While molecular methods have been proven to eliminate much of the inherent bias associated with culture-dependent community analyses, it was recognized that cultureable bacteria are vital contributors in many biochemical cycling processes in the aquatic environment and should be regarded as an important component of the community.

In light of this consideration, community-level physiological profiling (CLPP) was employed to characterize the community functionality by assessing the potential of the cultureable community, as a whole, to degrade an array of provided carbon sources. Since microorganisms adapt rapidly to changing environmental conditions (*i.e.* spatial and temporal variation), alterations in community structure and function can serve as effective indicators of overall changes in environmental quality (Kennedy and Papendick, 1995; Pankhurst *et al.*, 1997). Therefore, we adopted an integrative approach that combined bacterial community structure and functional analyses to characterize the impact. In particular, functional profiles were generated using CLPP to determine average metabolic rates, diversity, and richness, while DGGE-generated structural profiles provided insight with regard to the genetic diversity and richness of the sampled aquatic communities, in addition to their averaged banding patterns based on G+C content. Although the combination of CLPP and PCR-DGGE can effectively characterize the structure and functioning of communities, the use of these methods in concert to simultaneously characterize the microbial communities within flow-through and

recirculating aquaculture environments has not been extensively conducted.

Although there is a considerable volume of literature that implicates G+C content in prokaryotes as an important parameter of sequence variation within bacterial genomes that confers taxonomic information, (Bohlin *et al.*, 2010; Hildebrand *et al.*, 2010) it has been suggested that the G+C content may vary considerably in response to environmental selective pressures. Raghavan *et al.* (2012) explored this concept, and reported evidence of a positive correlation between the expression of increasing G+C content and bacterial fitness. According to the authors, this indicates that genomic mutations inferring fitness could be the driving factor for maintaining a higher G+C content, and that evidence of a G+C rich community may signify a more complex environment. Nonetheless, this is largely theory based and requires additional supporting evidence. In the context of this study, it was not possible to distinguish the taxonomic identity of individual OTU(s) within the DGGE genetic ‘fingerprint’ without excision and genetic sequencing. Nevertheless, the use of the term OTU maintains that DGGE bands may not be indicative of a specific taxon, but rather groups possessing similar melting points of the V3 region of 16S rDNA (Woese, 1987). Therefore, for the purpose of this discussion, a band will be considered a unique OTU, such that increasing band number denotes a wider taxonomic variety within the community.

CLPP and DGGE profiling results revealed a seasonal and spatial-driven shift in the microbial communities within the northern FTS-A. Communities obtained during colder climate months (February and November 2013) appeared to demonstrate greater similarity in functional profiles compared to communities sampled during warmer climate months (August 2013 and April 2014) (Figure 3.7). Although slower to metabolize the 31 carbon sources, as measured by AWCD values, communities sampled during the colder seasonal months

displayed the capacity to utilize 90% or greater of the supplied substrate following a 96 hour incubation period (Figure 3.7A; Figure 3.7C). Moreover, while functional diversity of the February and November communities was lower compared to other sampling months, the calculated H values of 3.2 or greater suggest maintenance of high diversity. This is consistent with the notion that microbial communities undergo gradual shifts in functionality throughout the year as a result of temperature variation (Rastogi and Sani, 2011). This fluctuating pattern appears to be cyclical based on season, but additional annual sampling is necessary in order to substantiate this trend. Nonetheless, it is suggested that lower catabolic activity observed in the February community is correlated to an increased physiological stress response in the select microbial species able to endure the seasonal temperature decrease (*i.e.* unfavourable conditions for a prolonged period).

Evidence of spatial variation in functional profiles was apparent for the FTS-A, such that the treatment pond displayed the most responsive functional profiles, as measured by AWCD, H, and R. It appears that, as the communities move through the FTS and are released into the treatment pond, experiencing the effects of ambient temperature and substrate loading (e.g. drum-filter solids disposal, feed and organic material accumulation), community functionality increases. Functional diversity, or the diversity of potential substrate utilization, is often used as an ecological surrogate measure for overall community health, and can be loosely interpreted as microbial diversity (Weber *et al.*, 2008). Diversity measures are a mixed measure including both number of species (or responsive wells in this case) and overall evenness distribution of all species in the community (*i.e.* similarity of well responses in this case). Weber and Legge (2010) have proposed that a microbial population with a higher diversity can readily handle acute disturbances and positively adapt to changing conditions

within the environment. From an aquaculture system perspective, it seems plausible to also imply that higher community diversity increases the likelihood that any one waste constituent (or available nutrient) will be degraded within the system due to the increased metabolic diversity associated with the community. Thus, in the context of this study, it is suggested that the communities within the treatment pond are functionally robust and resilient, retaining high diversity and metabolic capability throughout all seasons.

The structural profiles for the Northern system (FTS-A) are in agreement with functional trends, such that the treatment pond communities demonstrated a greater genetic integrity, as measured by structural diversity (H') and species richness (Figure 3.9A; Figure 3.9B). Notably, communities extracted from the polishing pond displayed highly similar structural profiles when compared to those from the treatment pond, which, while important, is not unexpected. As previously mentioned, increasing band number is implicated in the existence of a wider taxonomic variety in the community. Thus, it appears that the outdoor series of treatment ponds may promote functional and structural stability prior to discharge to the receiving environment. However, owing to the open nature of the system, community dynamics may be impacted by a variety of parameters. For instance, wildlife activities may have resulted in a shift in community richness within the treatment pond as a result of species introduction. In fact, this is evident with regard to the species richness and diversity values for the April 2014 event, whereby a noticeable increase in both measured parameters was apparent during this sampling event. During this late spring event in April, system operators indicated that a local beaver population had constructed dams in the treatment pond location, impeding water flow and causing settlement disturbance (Facility management personnel, personal communication, 2014). Moreover, the emergence of warmer weather may have contributed to

frequent instances of runoff and flooding in the on-site ponds. This natural phenomenon, along with the occurrence of rain events, may contribute to the mixing of water and the release of substrate and bacterial populations that may have settled to the bottom regions of the ponds. Under this scenario, an increase in species richness would be governed by the introduction of new microbial constituents. The results of our genetic profiling analyses support this hypothesis.

To further illustrate the structural profile of the microbial communities within the FTS-A, averaged banding patterns were created using the averaged relative abundances from the DGGE banding pattern, while maintaining respective migrating distances of individual OTUs (Figure 3.10). Results of banding patterns for all months revealed that the February community displayed the least expansive genetic profile compared to other months, with the majority of G+C content contained within large peaks between the 4th and 9th band movement group, indicative of taxonomically narrow communities with relatively low G+C content. As the temperature increased with seasonal progression, the movement groups of the August communities appeared to be more proportionally distributed, with the appearance of small peaks indicative of low G+C OTUs. The final sampling event in April revealed the emergence of OTU convergence in raceway and polishing pond samples. For instance, the raceway community was dominated by a single OTU accounting for over 60% of the total community representation with moderately low G+C content, while the polishing pond displayed two peaks with moderate to low G+C content OTUs encompassing the entire community. Aquaculture practices intensify during spring months (e.g. introduction of new broodstock and associated feeding regimes), and accompanied by the seasonal and environmental changes, the structural community dynamics may have been modified in such a way that OTUs with

moderate G+C content were able to flourish. Furthermore, this finding may indicate the February community dominated by niche populations able to withstand less favorable conditions. Huber *et al.* (2004) examined the microbial composition of the gut microflora of several fish species, and found that the community contained Gram-positive bacteria with high G+C content, and a predominance of Gram-negative bacteria with low G+C content. This further supports the findings from our structural profiling investigation, especially with regard to the distribution of band movement groups during intensive rearing seasons.

In the local flow-through system (FTS-B), CLPP results revealed that microbial communities obtained from the on-site pond and final discharge effluent displayed the highest functionality among all system locations, regardless of sampling date. In particular, AWCD and functional diversity trends (H') demonstrate the presence of a metabolically active and diverse population in the pond water supplying the system with influent water for rearing purposes, with measured values greater than 1.35 and 3.4, respectively (Figure 3.8). This pattern was similarly reflected with regard to the effluent samples, such that communities discharged to the receiving environment demonstrated the ability to rapidly metabolize all 31 carbon substrates and maintain a high diversity following passage through the system. The favorable environment offered by increased oxygen and nutrients (e.g. feed, fecal matter, suspended solids) associated with the aquaculture system are perhaps responsible for enhanced bacterial development in this aquatic environment.

This is supported by structural-related data, which revealed that the discharge effluent location harbored communities with elevated species diversity and richness compared to the other system locations (Figure 3.9). This likely indicates the presence of structurally resilient communities that may be more adept at handling disturbances such as nutrient fluctuation

(Kirk *et al.* 2005). In fact, the species richness index is considered a valuable parameter for measuring the fitness and flexibility of microbial communities (Wittebolle *et al.*, 2009; Yachi and Loreau, 1999). In this way, a decrease in richness is thought to negatively impact the functional stability of the community as a result of decreased productivity and capability to handle acute and chronic disturbances (*i.e.* nutrient availability, antibiotic treatment). Therefore, the observed recovery of richness and diversity in the discharge effluent samples may be an indication of the natural hardiness of select microorganisms able to persist despite unfavourable environmental conditions, and may serve as supporting evidence for the association between resistance and tolerance mechanisms in microbial communities exposed to anthropogenic and ecological disturbance. Shifts in the banding profiles generated for the June (2013) and May (2014) sampling events were evident with respect to the G+C content of the community (Figure 3.12). Banding profiles for the discharge effluent communities appear to maintain structural integrity from the initial June event to May of the following year. Conversely, communities within the location of the on-site pond demonstrate a significant shift in community structure from the initial to secondary sampling event, with the emergence of low G+C OTUs appearing. This may suggest that prevailing conditions within the pond may not have been conducive to the maintenance of a more G+C rich community, instead favouring a more G+C poor community during the seasonal period of May 2014. Results from this study, therefore, suggest that there is a complex relationship between microbial community integrity and prevailing environmental factors.

Whereas microbial community analyses using Biolog© MicroPlates™ have been described extensively in literature since the original description by Garland and Mills (1991), to our knowledge this is the first report that has utilized this approach to explicitly investigate

the communities of NBM and UF treated recirculating aquaculture systems. For this reason, a better comprehension of the functionality of these communities that play vital roles in the global nutrient cycling in RAS represented an opportunity to contribute to the knowledge. Overall, the influence of the different water treatment approaches on the microbial populations investigated was discernable enough to be identified using measures of both substrate and structural diversity.

A comparison of the functional and structural profiles of communities within RAS-A with those of RAS-B indicated that across the experimental monitoring period, the variation in measured CLPP and DGGE statistical indices was more pronounced in the UF treated system. The functional profiles of influent communities in RAS-A were analogous to those of the source water communities in RAS-B. Owing to the functional and structural resemblance, these profiles are likely an accurate reflection of the resident microbial communities within the larger field-scale recirculating system prior to treatment technology exposure. Furthermore, this similarity supports the comparative evaluation of communities exposed to the different water treatment approaches. Generally, these communities demonstrated statistical index values (e.g. H, AWCD and R) indicative of diverse populations able to rapidly metabolize all 31 provided carbon substrates in the EcoPlate™. Metabolic diversity as determined by the Shannon Index (H'), can be considered high with an H' value greater than 3 for all influent and source communities over the monitoring period (Figure 4.5B; Figure 4.6B).

Higher diversity within these samples is likely attributed to high availability of resources (*i.e.* nutrients and organic matter) as a result of rearing practices. The same general trend was observed across all sampling dates, whereby biofilm communities within the NMB appeared to have the greatest integrity, as expressed by physiological and structural diversity

(Figure 4.5B; Figure 4.7B). A reduction in functional diversity was observed during the sampling event on week 8, but was subsequently restored by week 10. Interestingly, structural profiles did not reflect this same trend, instead exhibiting minimal variation in species diversity and richness. This slight difference may suggest that the biofilm community within the NMB was not functioning at a steady-state condition.

The possibility that functional fingerprinting may be a useful indicator of steady-state conditions within bioreactors has previously been proposed by Osem *et al.* (2007). However, observed differences in the metabolic profiles among the sampling dates can also be attributed to changes in environmental conditions such as influent water quality, hydrologic flow, bioreactor retention time and biofilm growth (Hench *et al.*, 2003). These factors can interact with successional processes occurring within the attached microbial community. For instance, over-colonizing of the NMB substrate media may have resulted in a sloughing of the biofilm, resulting in a direct loss of functional diversity. Furthermore, the possibility of reaching steady-state conditions in such highly dynamic environments, particularly on an active and constantly developing surface area such as a NMB, is questionable. Although the communities within the NMB did not express the capacity to utilize all 31 carbon sources until approximately week 8, they remained significantly more metabolically active than influent and effluent communities throughout the entire monitoring period, based on richness and AWCD (590 nm) values (Figure 4.5A).

Compared to their planktonic counterparts, biofilm-associated communities have been shown to possess enhanced metabolic activity, as well as increased tolerance to physical treatments (Wietz *et al.*, 2009). It should be noted that studies comparing the functional diversities in microbial aggregates with those in corresponding planktonic communities are

scarce, particularly with regard to biological reactors treating aquaculture effluents. Following exposure to the NMB, microbial communities appear to have reduced functionality, such that diversity and metabolic rates of effluent communities are decreased compared to those within the biofilm. This may suggest that release from the protective biofilm matrix is correlated with a reduction in physiological functionality, likely due to increased competition and lower substrate availability.

Comparisons between community diversity among differing sample locations was reinforced by averaged banding patterns, which revealed greater band movement group distribution in the phylotypes (represented by bands or OTUs) constituting sessile communities from the NMB biofilms, compared to planktonic influent and effluent sources (Figure 4.8). While significant, this result was not unexpected, as biofilms forming in bioreactors have been reported to have a diverse bacterial community that is generally distinct compared to planktonic communities from rearing water (Bourne *et al.*, 2004). Bourne *et al.* (2006) investigated the genetic composition of biofilms during various stages of establishment and colonization, and found a dynamic succession of microbial species during biofilm development, which supports the results from this study. Interestingly, the banding profile generated from the biofilm contained phylogenetic members with both moderate and high G+C content, which may perhaps signify that taxa with low G+C content are more likely to be eliminated during the treatment process. Additionally, as previously indicated, a community with a higher G+C content may suggest a more complex environment. Therefore, it is proposed that the environment of the NMB may have provided selective pressures driving the increased fitness of the community within the biofilm matrix, and likely supported a community comprised of more phylogenetically distinct taxa than the rearing water outside of

the bioreactor. The appearance of distinct peaks in the effluent communities may signify that the microbial communities released from the NMB were comprised of a niche population comprised of taxa with moderate to low G+C content. Results from this study, thus suggest that there is a strong relationship between the NMB treatment process and community structure.

Comparatively, the functional profiles of microbial communities in the UF treated recirculating system (RAS-B) reveal a highly varied and distinct pattern of community functionality and composition across system compartments (Figure 4.6; Figure 4.7). Microbial communities extracted from the outlet of the ultra-filter demonstrated a significant reduction in functional and structural integrity, as expressed by CLPP and DGGE profiles of metabolic activity, diversity and richness. This is likely a direct result of the mechanism of action of this membrane filtration approach. The pore sizes of UF membranes are small enough (0.001- 0.1 μm) to ensure high (to complete) log removal of microbiological hazards, including pathogenic microorganisms and total bacterial counts (Hagen, 1998). As mentioned earlier, membrane filtration, such as the one employed in this study, are capable of high removal efficiencies of organic carbon, suspended solids and fine particulate matter from wastewater (Nakatsuka *et al.*, 1996; Castaing *et al.*, 2010). Therefore, mechanical removal of a large fraction of the overall microbial community and suspended solids within the rearing waters may have led to a direct reduction in functional diversity. Microbial communities may respond to a varying supply of substrates either by physiological adaptation, or by changes in the community composition (Pinhassi *et al.*, 1999), such that even small additions or shifts in organic substrate availability may trigger a corresponding shift in the composition of the community. This association was also reported by van Hannen *et al.* (1999) who investigated bench-scale

dilution cultures receiving detritus. Thus, it is proposed that the decreased functional diversity and catabolic activity of microbial communities in UF treated samples was linked to reduction in the heterotrophic populations through removal of nutrient availability, and an increased physiological stress response caused by shifts in nutrient availability in the select microbial species able to endure unfavourable environmental conditions. In general, there are no evident trends with respect to average banding patterns. Rather, it appears that the community experienced a frequent alteration in genetic structure, with the appearance and disappearance of novel G+C poor and G+C rich OTUs. This likely suggests that the UF does not promote the development of a structurally stable community. While not explicitly investigated, this variability in the community structure may give rise to the succession of opportunistic pathogens in the system as a consequence of niche availability and reduced competitive pressures. The implications of this should be further explored in order to determine the applicability of this technology in recirculating systems.

The metabolic analysis of microbial communities using Biolog plates has several caveats. First, it is strongly biased towards the cultureable, rapidly-growing heterotrophic species (Michaud *et al.*, 2006). Secondly, the assay plates are biased through the inclusion of carbon sources favoring Gram-negative over Gram-positive bacteria (Garland and Mills, 1991). Third, the plate chemistry only detects aerobic respiration (Weber and Legge, 2010). Even with these limitations, EcoPlatesTM can still be useful in making generalized comparisons of the metabolic potential of the cultureable fraction of the community. It is interesting, but perhaps not surprising, that CLPP and DGGE analyses resulted in some contrasting views concerning the distribution of bacterial diversity in the aquaculture systems. CLPP is a measure of potential physiological diversity, not actual catabolic activity (Weber *et al.*, 2011).

Furthermore, CLPP is a selective enrichment since positive color development in the wells of EcoPlates™ can be caused by active respiration and growth of a limited number of organisms. Much like CLPP, limitations of DGGE should also be considered when interpreting data. DGGE provides an estimate of actual genetic diversity of the dominant members of microbial communities, but also is subject to limitations such as the method of DNA extraction and PCR bias (Weber and Legge, 2008), and reveals information unrelated to the activity of microbial populations. Typically, cells must constitute at least 1% of the total microbial population to provide a visible band on DGGE gels (Calbrix *et al.*, 2001), and as previously mentioned in Chapter 1, may account for an underrepresentation of the ‘true’ community.

The mechanism by which aquatic bacteria respond to treatment technology in a recirculating system is still not fully known, but the present study provides some evidence in this regard. The effect of treatment approach is clearly linked to shifts in the functional and structural profiles of the community, such that a more stable community is supported by the NMB compared to the the UF. In both pilot-scale systems, the only differing variable appeared to be the type of treatment technology employed within the system. Overall, this study constitutes the first investigation of NMB technology and UF technology influence on bacterial community composition and function in freshwater recirculating aquaculture systems. The results demonstrated a technology-driven substantial shift in microbial population in the two pilot-scale systems, and provide guidance for aquatic animal disease control in fish aquaculture. Furthermore, this study constitutes an important step toward extending our knowledge of environmental microbiology in recirculating aquaculture systems.

Chapter 6: Overall Conclusions

6.1 Research Overview

Bacterial communities within diverse aquaculture environments were assessed through the use of complementary, yet distinct profiling methods. Traditional microbiological cultivation was used to investigate the presence and enumeration of bacteria of interest, including total heterotrophic bacteria counts (HPC), and the fish pathogens *Yersinia* spp. and *Aeromonas* spp. CLPP with Biolog EcoPlatesTM were used to assess the metabolic diversity and functionality of heterotrophic microbial populations, while DGGE was used to assess changes in the overall community composition using the 16S rRNA gene. Overall, computation of statistical indices for CLPP and DGGE data provided a comprehensive image of the respective communities. While exact taxonomic identities and numbers of microbial species responsible for substrate utilization remain unknown, the pattern of functional diversity both within and among communities yields insight where understanding is currently lacking.

6.2 Summary of Major Findings

- 1) Functional and structural profiling results revealed discernable differences in the composition and functionality of communities extracted from different aquatic environments (including open and closed aquaculture systems). Overall, seasonal variation within the Northern aquaculture system appeared to induce shifts in the community composition that resulted in a reduction of overall community diversity and metabolic capability.
- 2) During summer seasonal events, the progression of communities through the local and Northern systems appeared to promote improvements in community integrity, with

enhanced functional and structural diversity observed in the communities extracted from treatment ponds and discharge locations. This may indicate the potential for dissemination of more robust and resilient communities to receiving water bodies.

- 3) A comparison CLPP and DGGE data from the pilot-scale recirculating systems revealed the potential for the NMB system to support a more diverse and stable community over time, with the NMB potentially functioning to increase physiological status of microorganisms following exposure. In comparison, exposure to the ultra-filtration technology appeared to result in a marked loss in community integrity, with
- 4) The relative abundance of cultureable fecal indicator organisms *E. coli* and *Enterococcus* spp. were not detected in statistically relevant concentrations in the two pilot-scale recirculating aquaculture systems, and were only found in low abundances within the flow-through system environments. Conversely, pathogens from the genera *Yersinia* and *Aeromonas* were found in relatively high abundances in all of the investigated aquaculture systems. This indicates the reliability of these microorganisms as fecal indicators may need to be reconsidered.
- 5) Overall, across all sampling sites, cultivation data revealed a greater prevalence of pathogenic organisms from the genus *Yersinia* compared to *Aeromonas* spp. This may indicate that rearing conditions favour the growth of *Yersinia* spp.
- 6) Antibiotic resistance expression by *Yersinia* spp. and *Aeromonas* spp. cultivated from the local flow-through aquaculture system indicated an increasing trend in MDR frequency following passage through the system compartments. While sampling events were limited to summer months, it is suggested that increased resistance may be a result of the physiological response to the prevailing combination of environmental and

anthropogenic stresses imposed within the rearing environment.

- 7) As revealed by the antibiotic profiling results of the local flow-through system (FTS-B), following prophylactic and therapeutic antibiotic treatment, waterborne *Yersinia* spp. and *Aeromonas* spp. exhibited enhanced tolerance to a panel of clinically relevant antibiotics, and were more likely to exhibit MDR. Additionally, MDR frequencies were observed to increase following progression through the system compartments, which may suggest that those organisms able to withstand the prevailing conditions in the system are more physiologically robust. This may be important when considering the dissemination of these pathogens to receiving water bodies through the discharging of effluent waters.

6.3 Future Research

As aquaculture practices continue to intensify, their success will lie, in part, not only in continuing to identify essential microorganisms associated with specific processes, but also in understanding how they contribute within their consortium to achieve efficient and stable activities. As such, the following provides a simplified description of potential avenues for future research in the field of environmental microbiology.

- 1) In an effort to better elucidate the presence and occurrence of pathogens within aquaculture systems, the use of quantitative PCR (qPCR) is recommended for future studies. This will allow for the explicit quantification of species of interest, both viable and viable but noncultureable (VBNC), and may help to circumvent the inherent bias associated with traditional cultivation techniques.
- 2) Application of the methods outlined in the pilot-scale study to a full-scale setting may prove highly useful for understanding the bacterial community dynamics in full-scale

systems, perhaps allowing for increased performance predictions and enhanced performance control, making RAS treatment technologies more viable and reliable for management purposes.

- 3) Additional studies should also be carried out that centre on the impact of microbial community integrity on the occurrence, fate, and transmission of antibiotic resistance in the constituent pathogenic population. To that end, although literature indicates considerable work has been carried out regarding the transfer of resistance genes in natural aquatic environments, transfer in more life-like scenarios should be examined further. This could be carried out using whole bacterial communities, or with the use of labeled bacteria or labeled resistance genes to monitor the effects at the single-cell level. The areas that could be addressed are transfer in a mixed bacterial community, and interaction with the indigenous aquatic bacteria.
- 4) Although the low number of isolates cultivated in this study did not permit for extensive antibiotic resistance testing, continued surveillance of antibiotic resistance in these highly productive aquaculture systems is highly recommended. The potential dissemination of multi-drug resistant pathogens of human and animal significance to the broader environment certainly warrants continued investigation.
- 5) Advancements in molecular microbiology, such as non-culture based techniques and high throughput DNA sequencing technology have evolved the field of environmental microbiology. In light of this, future studies may focus on the excision of bands within DGGE gels in an effort to obtain sequence specific data, which may contribute to a better understanding of the community shifts and composition.

6.4 Concluding Remarks and Integrative Nature of Thesis

In the current study, it was apparent that bacterial communities respond in dynamic ways to differing environments and selective pressures. Whether the system design is ‘open’ or ‘closed’, shifts in community function and structure are evident with regard to a multitude of parameters. Factors such as source water quality, suspended solids removal, seasonal fluctuations and wastewater treatment technologies all have a prominent effect on the community constituents. The research presented in this thesis adds context to the understanding of microbial management in highly productive aquaculture systems. While enhanced experimental rigor (e.g. assessment of treatment technology in a full scale vs. pilot-scale system, and the low number of isolates tested in the ABR profiling) is necessary for the development of governing policies concerning aquaculture in Canada, the research in this study has laid the groundwork on which to consider modification or implementation of aquaculture management strategies.

The integrative nature of this thesis should be evident throughout this document, visible first and foremost in the use of multiple techniques that measure different hierarchies of biological organization, through both physiological (functional profiling) and evolutionary (molecular-driven investigation) changes. Aquatic environments were monitored in both their natural states, but also in response to an engineered treatment technology. By taking a more multiphasic approach, a more comprehensive understanding of the inherently complex concept of community dynamics was possible. Additionally, this project involved numerous collaborative efforts with associates from multiple disciplines, including: engineering, chemistry, animal health and industry. In fact, this study was the first to investigate the

community response to NMB technology, and as such, contributes the initial foundation on which future work begin. Therefore, the uniqueness and significance of this study is apparent on a multitude of levels, including the design of the research question, and the approach to investigation and interpretation.

References

- Abulreesh H.H., Paget T.A., Goulder R. 2004. Waterfowl and the bacteriological quality of amenity ponds. *Journal of Water and Health* 2(3):183-189.
- Ackefors H., Enell M. 1990. Discharge of nutrients from Swedish fish farming to adjacent sea areas. *Ambio* 19(1): 28-35.
- Allen M.J., Edberg S.C. Reasoner D.J., 2004. Heterotrophic plate count bacteria-what is their significance in drinking water? *International Journal of Food Microbiology* 92:265-274.
- Amann R.I., Ludwig W., Schleifer K.H. 1995. Phylogenetic identification and in situ detection of individual microbial cells without cultivation. *Microbiological Reviews* 59: 143-169.
- American Public Health Association (APHA). 1998. Standard methods for the examination of water and wastewater, 20th ed. American Water Work Association and Water Environment Federation; Washington, D.C.
- Ansari M., Rahimi E., Raissy M. 2011. Antibiotic susceptibility and resistance of *Aeromonas* spp. isolated from fish. *African Journal of Microbiology Research* 5(31): 5572-5775.
- Araújo V.S., Pagliares V.A., Queiroz M.L.P., Freitas-Almeida A.C. 2002. Occurrence of *Staphylococcus* and enteropathogens in soft cheese commercialized in the city of Rio de Janeiro, Brazil. *Journal of Applied Microbiology* 92(6): 1172-1177.
- Asche F., 2010. Aquaculture-Opportunities and Challenges: Special Issue Introduction. *Marine resource economics* 23:395.
- Ashbolt N. J., Grabow W. O. K., Snozzi M. 2001. Indicators of microbial water quality. In: Fewtrell, L. and Bartram, J. (ed.) *Water Quality: Guidelines, Standards and Health*. IWA Publishing, London, pp. 289– 315.
- Atlas R.M., Bartha R. 1998. Microbial ecology: fundamentals and applications. Benjamin/Cummings Publishing Company Inc. Redwood City, CA.
- Attramadal K.J.K., Salvesen I., Xue R., Øie G., Størseth T.R., Vadstein O., Olsen Y. 2012. Recirculation as a possible microbial control strategy in the production of marine larvae. *Aquacultural Engineering* 46: 27–39.

- Austin B. 2009. Vibrios as causal agents of zoonoses *Veterinary Microbiology* 140: 310-317.
- Balebona M.C, Morinigo M.A., Borrego J.J. 2001. Hydrophobicity and adhesion to fish cells and mucus of *Vibrio* strains isolated from infected fish. *International Microbiology* 4: 21–26
- Baquero F., Martinez J.L., Canton R. 2008. Antibiotics and antibiotic resistance in water environments. *Current Opinion in Biotechnology* 19(3): 260-265.
- [BD™] Buffered Peptone Water [Internet]. 2011. [cited 2013 April 1]. Available from <http://www.bd.com/resource.aspx?IDX=23342>.
- BIOLOG, Inc. BIOLOG EcoPlate™ Microbial Community Analysis [Internet]. Hayward (CA) [cited 2013 April 1]. Available from <http://www.BIOLOG™.com>.
- Blancheton J.P. 2000. Development in recirculation systems for Mediterranean fish species. *Aquacultural Engineering* 22: 17-31.
- Blancheton J.P., Attramadal K.J.K., Michaud L., Roque d'Orbcastele E., Vadstein O. 2013. Insight into bacterial population in aquaculture systems and its implication. *Aquacultural Engineering* 53:30-39.
- Bockelmann U., Dorries H-H., Ayuso-Gabella M.N., Slgot de Marçay M. Tandoi V., Levantesi C., Masciopinto C., Van Houtte E., Szewzyk U., Wubtgens T., Grohmann E. 2009. Quantitative PCR monitoring of antibiotic resistance genes and bacterial pathogens in three European artificial groundwater recharge systems. *Applied and Environmental Microbiology* 75:154-163.
- Bonardi S., Paris A., Bassai L., Salmi F., Bacci C., Riboldi E., Boni E., D'Incau M., Taliabue S., Brindani F. 2010. Detection, semiquantitative enumeration, and antimicrobial susceptibility of *Yersinia enterocolitica* in pork and chicken meats in Italy. *Journal of Food Protection* 73:1785-1792.
- Bourne D.G, Young N, Webster N, Payne M, Salmon M, Demel S, Hall M. 2004. Microbial community dynamics in a larval aquaculture system of the tropical rock lobster, *Panulirus ornatus*. *Aquaculture* 242:31-51.

- Calbrix R., Barray S., Laval K. 2005. Analysis of potential functional diversity of soil bacterial community using sole-carbon-utilization profiles: A reproducible procedure. *European Journal of Soil Biology* 41:11-20.
- Castaing J.B., Massé A., Pontié M., Séchet V., Haure J., Jaouen P. 2010. Investigating submerged ultrafiltration (UF) and microfiltration (MF) membranes for seawater pre-treatment dedicated to total removal of undesirable micro-algae. *Desalination* 253:71-77.
- Centers for Disease Control and Prevention [CDC]. 2013. Human deaths and third-generation cephalosporin use in poultry, Europe [Internet]. Available at http://wwwnc.cdc.gov/eid/article.19.8.12-0681_article.html.
- Chopra I., Roberts M. 2001. Tetracycline antibiotics: mode of action applications, molecular biology, and epidemiology of bacterial resistance. *Microbiology and Molecular Biology Reviews*. 65:232-260.
- Clinical and Laboratory Standards Institute (CLSI) [Internet]. 2007. Methods for antimicrobial disk susceptibility testing of bacterial isolated from aquatic animals; approved guideline. [cited 2013 September 6] Available from <http://www.clsi.org/source/orders/freeim42-A/pdf> Accessed 12 April 2013.
- Coquet L, Cosette P, Quillet L, Petit F, Junter G-A, Jouenne T. 2002a. Occurrence and phenotypic characterization of *Yersinia ruckeri* strains with biofilm-forming capacity in a rainbow trout farm. *Applied Environmental Microbiology* 68: 470–475
- Coquet L, Cosette P, Junter G-A, Beucher, E, Saiter, J-M, Jouenne, T. 2002b. Adhesion of *Yersinia ruckeri* to fish farm materials: influence of cell and material surface properties. *Colloids and Surfaces B:Biointerfaces* 26: 373–378.
- Cottee S., Petersan P. 2009. Animal Welfare and Organic Aquaculture in Open Systems. *Journal of agricultural and environmental ethics* 22:437-461.
- Cripps S.J., Bergheim A. 2000. Solids management and removal for intensive land-based aquaculture production systems. *Aquacultural Engineering* 22(2): 33-56.
- Crocket C.S. 2007. The role of wastewater treatment in protecting water supplies against emerging pathogens. *Water Environment Reviews* 79: 221-232.
- Dahiya I., Stevenson R.M.W. 2002. *Yersinia ruckeri* genes that attenuate survival in rainbow trout (*Oncorhynchus mykiss*) are identified using signature-tagged mutants. *Veterinary*

Microbiology 144: 399-404.

- Dalsgaard, I., Madsen, L., 2000. Bacterial pathogens in rainbow trout, *Oncorhynchus mykiss* (Walbaum), reared at Danish freshwater farms. *Journal of Fish Diseases* 23:199-209.
- DePaola, A., Peeler, J.T., Rodrick, G.E. 1995. Effect of oxytetracycline-medicated feed on antibiotic resistance of Gram-negative bacteria in catfish ponds. *Applied Environmental Microbiology* 61: 2335-2340.
- FAO, 2010. The State of World Fisheries and Aquaculture 2010. Food and Agriculture Organization of the United Nations, Rome.
- Ferguson D., Signoretto C. 2011. Environmental persistence and naturalization of fecal indicator bacteria organisms. *Microbial Source Tracking: Methods, Applications and Case Studies* 17:379-397.
- Fromin, N., Hamelin J., Tarnawski S., Roesti D., Jourdain-Miserez K., Forestier N., Teyssier-Cuvelle S., Gillet F., Aragno M., Rossi P. 2002. Statistical analysis of denaturing gel electrophoresis (DGGE) fingerprinting patterns. *Environmental Microbiology* 4(11):634-643.
- Garland J.L. 1997. Analysis and interpretation of community-level physiological profiles in microbial ecology. *FEMS Microbiology Ecology* 24: 289-300.
- Garland J.L., Cook K.L., Loader C.A., Hungate B.A. 1997. The influence of microbial community structure and function on community-level physiological profiles - In: (Insam, H. and Rangger, A., Eds.) *Microbial Communities: functional versus structural approaches*, Springer, Hiedelberg, 171-183.
- Garland J.L. and Mills A.L. 1991. Classification and characterization of heterotrophic microbial communities on the basis of patterns of community-level sole-carbon source utilization. *Applied and Environmental Microbiology* 57 (8): 2351-2539.
- Gavin R, Merino S, Altarriba M, Canals R, Shaw JG, Tomas JM. 2003. Lateral flagella are required for increased cell adherence, invasion and biofilm formation in *Aeromonas* spp. *FEMS Microbiology Letters* 224: 77-83.
- Ghenghesh K.S., Ahmed S.F., El-Khalek R.A., Al-Gendy A., Klena J. 2008. *Aeromonas* infections in developing countries. *Journal of Infection in Developing Countries* 2(2): 81-89.

- Glucina, K., Alvarez, A., Laine, J.M., 2000. Assessment of an integrated membrane system for surface water treatment. *Desalination* 132:73-82.
- Green, S.I, Leigh, M.B., Neufeld, J.D. 2009. Denaturing gradient gel electrophoresis (DGGE) for microbial community analysis. In: Timmins, K.N. (ed). *Microbiology of Hydrocarbons, Oils, Lipids and Derived Compounds*. Springer-Verlag. Heidelberg, Germany. Pp. 4137-4158.
- Grove J.A., Kautola H., Javadpour S., Moo-Young M., Anderson W.A. 2004. Assessment of changes in the microorganism community in a biofilter. *Biochemical Engineering Journal* 18: 111-114.
- Guo, X., Zhang, Z., Fang, L., Su, L., 2009. Study on ultrafiltration for surface water by a polyvinylchloride hollow fiber membrane. *Desalination* 238: 183-191.
- Gutierrez-Wing M.T., Malone R.F. 2006. Biological filters in aquaculture: trends and research directions for freshwater and marine applications. *Aquacultural Engineering* 34: 163-171.
- Hanninen M.-L., Oivanen P., Hirvela -Koski V. 1997. *Aeromonas* species in fish, fish-eggs, shrimp and freshwater. *International Journal of Food Microbiology* 34:17–26.
- Hastings P.J., Rosenberg S.M., Slack A. 2004. Antibiotic-induced lateral transfer of antibiotic resistance. *Trends in Microbiology* 12 (9):401-404.
- Hench K.R., Bissonnette G.K., Sexstone A.J., Coleman J.G., Garbutt K.G., Shousen J.G. 2003. Fate of physical, chemical and microbial contaminants in domestic wastewater following treatment by small constructed wetlands. *Water Research* 37:921-927.
- Hildebrand F., Meyer A., Eyre-Walker A. 2010. Evidence of selection upon genomic GC-content in bacteria. *PLOS Genetics* 6(9):e1001107.
- Hugenholtz P. 2002. Exploring prokaryotic diversity in the genomic era. *Genome Biology* 3(2):0003.1-0003.8.
- Huys G., Kersters I., Coopman R., Janssen P., Kersters K. 1996. Genotypic diversity among *Aeromonas* isolates recovered from drinking water production plants as revealed by AFLPTM analysis. *Systematic and Applied Microbiology* 19:428–435.

- Ivanova E.P., Zhukova N.V., Gorshkova N.M., Chaikina E.L. 2001. Characterization of *Aeromonas* and *Vibrio* species isolated from a drinking water reservoir. *Journal of Applied Microbiology* 90:919–927.
- Kadlec R.H. 1999. Chemical, Physical and Biological Cycles in Treatment Wetlands. *Water Science and Technology* 40:37-44.
- Kennedy A.C., Papndick R.I. 1995. Microbial characteristics of soil quality. *Journal of Soil and Water Conservation* 6:1052-1060.
- Kirk J.L., Beaudette L.A., Hart M., Moutoglis P., Klironomoas J.N., Lee H., Trevors J T. 2004. Methods of studying soil microbial diversity. *Journal of Microbiological Methods* 58:169-188.
- Kirkan S., Goksoy E.O., Kaya O. 2000. The isolation of *Yersinia ruckeri* from rainbow trout in Aydin region. *Veterinary Microbiology and Disease* 31: 27-30.
- Klein B. U., Siesenop U., Boehm K. H. 1996. Investigations on transferable antibiotic resistance through R-plasmids between obligate and facultative fish pathogenic bacteria. *Bulletin of the European Association of Fish Pathology*. 16:13-142.
- Kuznetsov V.G., Timchenko N.F. 1998. Interactions between bacteria of the genus *Yersinia* in a water environment. *Journal of Microbial Epidemiology* 6: 26-29.
- Kwaga, J., Iversen, J. O. 1990. In vitro antimicrobial susceptibilities of *Yersinia enterocolitica* and related species isolated from slaughtered pigs and pork products. *Antimicrobial Agents and Chemotherapy* 34: 2423–2425.
- Léonard N., Blancheton J.P., Guiraud J.P. 2000. Populations of heterotrophic bacteria in an experimental recirculating aquaculture system. *Aquaculture* 22: 109 -120.
- Léonard N., Guiraud J.P., Gasset, E., Caillères, J.P., Blancheton, J.P. 2002. Bacteria and nutrients – nitrogen and carbon – in a recirculating system for sea bass production . *Aquaculture Engineering* 26: 111-127.
- Losordo T.M., Masser M.P., Rakocy J. 1998. Recirculating aquaculture tank production systems: an overview of critical considerations - Southern Regional Aquaculture Center Publication No. 451.
- Luo C., Walk S.T., Gordon D.M., Feldgarden M., Tiedje J.M., Konstantinidis, K.T. Genome sequencing of environmental *Escherichia coli* expands understanding of the ecology

and speciation of the model bacteria species. *Proceedings of the National Academy of the Sciences of the United States of America* 108 (17): 7200-7205.

- Madigan M.T., Martinko J.M., Dunlap P.V., Clark D.P. 2009. Brock: Biology of microorganisms 12th ed. Pearson Education Inc. Publishing. San Francisco, CA. pp. 179-182.
- Malik S., Beer M., Megharaj M., Naidu R. 2008. The use of molecular techniques to characterize the microbial communities in contaminated soil and water. *Environment International* 34:265-276.
- Massa S., Caruso M., Trovatelli F., Tosques M. 1998. Comparison of plate count agar and R2A medium for enumeration of heterotrophic bacteria in natural mineral water. *World Journal of Microbiology and Biotechnology* 14: 727-730.
- McMahon M.A.S., Xu J., Moore J.E., Blair., McDowell D.A. 2007. Environmental stress and antibiotic resistance in food-related pathogens. *Applied and Environmental Microbiology* 73(1): 211-217.
- Michaud L., Blancheton J.P., Bruni V., Piedrahita R. 2006. Effect of particulate organic carbon on heterotrophic bacterial populations and nitrification efficiency in biological filters. *Aquacultural Engineering* 34: 224-233.
- Michaud L., Lo Giudice A., Troussellier M., Smedile F., Bruni V., Blancheton J.P. 2009. Phylogenetic characterization of the heterotrophic bacterial communities inhabiting a marine recirculating aquaculture system. *Journal of Applied Microbiology* 107: 1935-1946.
- Miranda C.D., Kehrenberg C., Ulep C., Schwarz S., Roberts M.C. 2003. Diversity of tetracycline-resistance genes in bacteria from Chilean salmon farms. *Antimicrobial Agents in Chemotherapy* 47: 883-888.
- Miranda C.D., Zemelman R. 2002. Bacterial resistance to oxytetracycline in Chilean salmon farming. *Aquaculture* 212: 31-47.
- Moriarty, D.J.W., 1997. The role of microorganisms in aquaculture ponds. *Aquaculture* 151, 333-349.
- Muyzer G., De Waal E.C., Uitterlinden A.G. 1993. Profiling of Complex Microbial Populations by Denaturing Gradient Gel Electrophoresis Analysis of Polymerase

Chain Reaction-Amplified Genes Coding for 16S rRNA. *Applied and Environmental Microbiology* 59:695-700.

- Muyzer G., Smalla K. 1998. Applications of denaturing gradient gel electrophoresis (DGGE) and temperature gradient gel electrophoresis (TGGE) in microbial ecology. *Antonie van Leeuwenhoek* 73:127-141.
- Nakatsuka S., Nakate I., Miyano T., 1996. Drinking water treatment by using ultrafiltration hollow fiber membranes. *Desalination* 106: 55-61.
- Naylor R.L., Goldberg R.J., Primavera J.H., Kautsky N., Beveridge M.C.M., Clay J., Folke C., Lubchenco J., Mooney H., Troell M. 2000. Effect of aquaculture on world fish supplies. *Nature* 405:1017-1024.
- Nocker A., Burr M., Camper A.K. 2007. Genotypic microbial community profiling; a critical technical review. *Microbiology Engineering* 54: 276-289.
- Nubel U., Engelen B., Felske A, Snaidr I., Wieshuber A, Amann R. 1., Ludwig W., Backhaus H. 1996. Sequence heterogeneities of genes encoding 16S rRNAs in *Paenibacillus polymyxa* detected by temperature gradient gel electrophoresis. *Journal of Bacteriology* 178:5636-5643.
- Ogino A, Koshikawa H., Nakahara T., Uchiyama H. 2001. Succession of microbial communities during a biostimulation process as evaluated by DGGE and clone library analysis. *Journal of Applied Microbiology* 91:625-635.
- Oliver J.D. 2005. The viable but nonculturable state in bacteria. *The Journal of Microbiology* 43:93-100.
- Osem Y., Chen Y., Levinson D., Hader Y. The effects of plant roots on microbial community structure in aerated wastewater-treatment reactors. *Ecological Engineering* 29(2): 133-142.
- Pankhurst C.E., Hawke B. G., McDonald H.J., Kirkby C.A., Buckerfield J.C., Michelson P., O'Brien K.A., Gupta V.V.S.R., Doube B.M. 1995. Evaluation of soil biological properties as potential bioindicators of soil health. *Journal of Experimental Agriculture* 35:1015-1028.
- Perron G.G., Lee A.E., Wany Y., Huang W.E., Barraclough T.G. 2012. Bacterial recombination promotes the evolution of multi-drug resistance in functionally diverse

- populations. *Proceedings of the Royal Society B* 279:1477-1484.
- Petersen A., Andersen J.S., Kaewmak T., Somsiri T., Dalsgaard A. 2002. Impact of integrated fish farming on antimicrobial resistance in a pond environment. *Applied Environmental Microbiology* 68: 6036-6042.
- Pinhassi J., Azam F., Hemphälä J., Long R.A., Martinez J, Zweifel U.L., Hagström Å. 1999. Coupling between bacterioplankton species composition, population dynamics, and organic matter degradation. *Aquatic Microbial Ecology* 17:13-26.
- Prescott J.F., Baggot J.D., Walker R.D (ed.) 2000. Antimicrobial therapy in veterinary epidemiology, 3rd ed. Iowa State University Press, Ames.
- Quang S. 1994. Application of a microbiological monitoring technique for the assessment and steady-state operation in a wastewater treatment system.
- Raghavan R., Kelkar Y.D., Ochman H. 2012. A selective force favoring increased G+C content in bacterial genes. *Proceedings of the National Academy of Sciences of the United States of America* 109(36):14504-14507.
- Rastogi G., Sani RK. 2011. Molecular techniques to assess microbial community structure, function, and dynamics in the environment. Chapter 2: *Microbes and Microbial Technology: Agricultural and Environmental Applications*. Springer Publishing. New York, NY. pp. 29-40.
- Ritalahti K.M., Amos B.K., Sung Y., WU Q., Koenigsberg S.S., Löffler F.E. 2006. Quantitative PCR targeting 16S rRNA and reductive dehalogenase genes simultaneously monitors multiple *Dehalococcoides* Strains. *Applied and Environmental Microbiology* 72(4): 2765-2774.
- Sandaa R-A., Torsvik V.L., Gokscyr J. 1992. Transferable drug resistance in bacteria from fish-farm sediments. *Canadian Journal of Microbiology* 38:1061-1065.
- Sanz, J.L., Köchling, T. 2007. Molecular biology techniques used in wastewater treatment: An overview. *Process Biochemistry* 42:119-133.
- Schmidt A.S., Bruun M.S., Dalsgaard I., Pedersen K., Larsen J.L. 2000. Occurrence of antimicrobial resistance in fish-pathogenic and environmental bacteria associated with four Danish rainbow trout farms. *Applied Environmental Microbiology*. 66: 4908-4915.

- Schreier H.J., Mirzoyan N., Saito K. 2010. Microbial diversity of biological filters in recirculating aquaculture systems. *Current Opinion in Biotechnology* 21: 318–325.
- Shannon C.E. 1948. A mathematical theory of communication. *Bell System Technical Journal* 27: 379-423 and 623-656.
- Sharrer, M.J., Tal, Y., Ferrier, D., Hankins, J.A., Summerfelt, S.T. 2007. Membrane biological reactor treatment of a saline backwash flow from a recirculating aquaculture system. *Aquacultural Engineering* 36 (2), 159-176.
- Sharrer, M.J., Rishel, K., Summerfelt, S. 2009. Evaluation of geotextile filtration applying coagulant and flocculant amendments for aquaculture biosolids dewatering and phosphorus removal. *Aquacultural Engineering* 40, 1-10.
- Skjermo J., Salvesen I., Øie G., Olsen Y., Vadstein O. 1997. Microbially matured water: a technique for selection of a non-opportunistic bacterial flora in water that may improve performance of marine larvae. *Aquaculture International* 5: 13–28.
- Smith P., Hiney M., Samuelsen O.B. 1994. Bacterial resistance to antimicrobial agents used in fish farming: a critical evaluation of method and meaning. *Annual Review of Fish Diseases*.4: 273–313.
- Snow A., Anderson B., Wootton B. 2012. Flow-through land-based aquaculture wastewater and its treatment in subsurface flow constructed wetlands. *Environmental Reviews* 20: 54-69.
- Stickney R.R., 1994. Principles of aquaculture. Wiley, New York.
- Tiquia SM, Schleibak M, Schlaff J, Floyd C, Benipal B, Zakhem E, Murray KS.2008. Microbial community profiling and characterization of some heterotrophic bacterial I isolates from river waters and shallow groundwater wells along the Rouge River, southeast Michigan. *Environmental Technology*(6):651-663.
- Tzelepi E., Arvanitidou M., Mavroidi A., Tsakris A. 1999. Antibiotic susceptibilities of *Yersinia enterocolitica* and *Y. intermedia* isolates from aquatic environments. *Journal of Medical Microbiology*. 48: 157-160.
- United States Environmental Protection Agency (EPA), Method 1605. 2001. *Aeromonas* in Finished Water by Membrane filtration using Ampicillin-Dextrin Agar with Vancomycin (ADA-V), United States Environmental Protection Agency, Washington,

DC, USA.

- Van Elsas J.D., Semenov A.V., Costa R, Trevors I.T. 2011. Survival of *Escherichia coli* in the environment: Fundamental and public health aspects. *International Society of Microbial Ecology*. 5:173-183.
- van Hannen E. J., Mooij M. P., Van Agterveld H., Laanbroek H. J. 1999. Detritus-dependent development of microbial community in an experimental system: qualitative analysis by denaturing gradient gel electrophoresis. *Applied Environmental Microbiology* 65:2478-2484.
- van Rijn J. 1996. The potential for integrated biological treatment systems in recirculating fish culture- A review. *Aquaculture* 139: 181-201.
- Vaughan S., Coyne R., Smith P. 1996. The critical importance of sample site in the determination of the frequency of oxytetracycline resistance in the effluent microflora of a freshwater fish farm. *Aquaculture* 139:47-54.
- Velkov V. V. 1999. How environmental factors regulate mutagenesis and gene transfer in microorganisms. *Journal of Biosciences* 24:529-559.
- von Graevenitz. 2007. The role of *Aeromonas* in diarrhea: a review. *Infection* 35(2): 59-64.
- von Sperling M, de Lemos Chernicharo C.A. 2005 (eds) Biological wastewater treatment in warm climate regions, Vol 1. IWA Publishing, London.
- Wannet W.J.B., Reessink M., Brunings H.A., Maas H.M.E. 2001. Detection of pathogenic *Yersinia enterocolitica* by a rapid and sensitive duplex PCR assay. 39: 4483-4486.
- Wayne L.G., Brenner D.J., Colwell R.R., Grimont P.A., Kandler O., Krichesvsky M.I., Moore W.E., Murray R.G., Stackebrandt E., Starr M.P., Truper H.G. 1987. Report of the Ad Hoc Committee on reconciliation of approaches to bacterial systematics. *International Journal of Systematic Bacteriology* 37:463-464.
- Weber K.P., Gehder M.G., Legge R.L, 2008. Assessment of changes in the microbial community of constructed wetland mesocosms in response to acid mine drainage exposure. *Water Research* 42:780-188.
- Weber K.P., Legge R.L. 2010. Method for the detachment of culturable bacteria from wetland gravel. *Journal of Microbiological Methods* 80:242-250.

- Weber K.P., Mitzel M.R., Slawson R.M., Legge R.L. 2011. Effect of ciprofloxacin on microbiological development in wetland mesocosms. *Water Research* 45: 3185-3196.
- Wietz M., Halla M.R., Høj L. 2009. Effects of seawater ozonation on biofilm development in aquaculture tanks. *Systematic and Applied Microbiology* 32: 266- 277.
- Wright, G.D. 2007. The antibiotic resistome: the nexus of chemical and genetic diversity. *National Reviews in Microbiology* 5: 175-186.
- Yamamoto S., Harayama S. 1996. PCR amplification and direct sequencing of *gyrB* genes with universal primers and their application to the detection and taxonomic analysis of *Pseudomonas putida* strains. *Applied Environmental Microbiology*. 61:1104-1109.
- Yáñez M.A., Catalán V., Apráiz D., Figueras M.J., Martínez-Murcia A.J. 2003. Phylogenetic analysis of members of the genus *Aeromonas* based on *gyrB* gene sequences. *International Journal of Systematic Evolutionary Microbiology* 53: 875-883.
- Ye Y. 1999. Historical consumption and future demand for fish and fishery products: Exploratory calculations for the years 2015/2030. *FAO Fisheries Circular* 125-130
- Zak J.C., Willig M.R., Moorhead D.L., Wildman H.G. 1994. Functional diversity of microbial communities: A quantitative approach. *Soil Biology and Biochemistry* 26(9): 1101-1108.
- Zhang T., Fang H.H.P. 2000. Digitization of DGGE (denaturing gradient gel electrophoresis) profile and cluster analysis of microbial communities. *Biotechnology Letters*. pp. 339-405.
- Zhu S., Chen S. 2001. Effects of organic carbon on nitrification rate in fixed film biofilters. *Aquaculture Engineering* 25: 1-11.

A- Supplementary Tables and Figures

Table A1. Antibiotic Classes of Antibiotics Used in Phenotype Profiling

Class of Antibiotic	Antibiotics tested for resistance	Spectrum
Cephalosporin	Cefotaxime (CTX30) Ceftriaxone (CRO30) Ceftazidime (CAZ30)	Broad-spectrum activity against Gram positive & Gram negative bacteria
Penicillin	Ampicillin (AM10) Amoxicillin (AMC30)	Activity against Gram positive & some Gram negative bacteria
Glycopeptide	Vancomycin (VA30)	Activity against Gram positive bacteria
Quinolones	Ciprofloxacin (CIP5)	Broad-spectrum activity against Gram positive & Gram negative bacteria
Sulfonamide	Trimethoprim-Sulfamethoxazole (SXT)	Activity against a wide range of Gram negative & Gram positives
Oxazolidinone	Linezolid (LZD30)	Active against most Gram positives
Aminoglycoside	Streptomycin (S10)	Activity against Gram positive & Gram negative bacteria
Tetracycline	Oxytetracycline (T30) Doxycycline (D30) Tetracycline (TE30)	Broad-spectrum activity against Gram positive & Gram negative bacteria
Other	Chloramphenicol (C30)	Activity against a wide variety of Gram negative and Gram positive bacteria

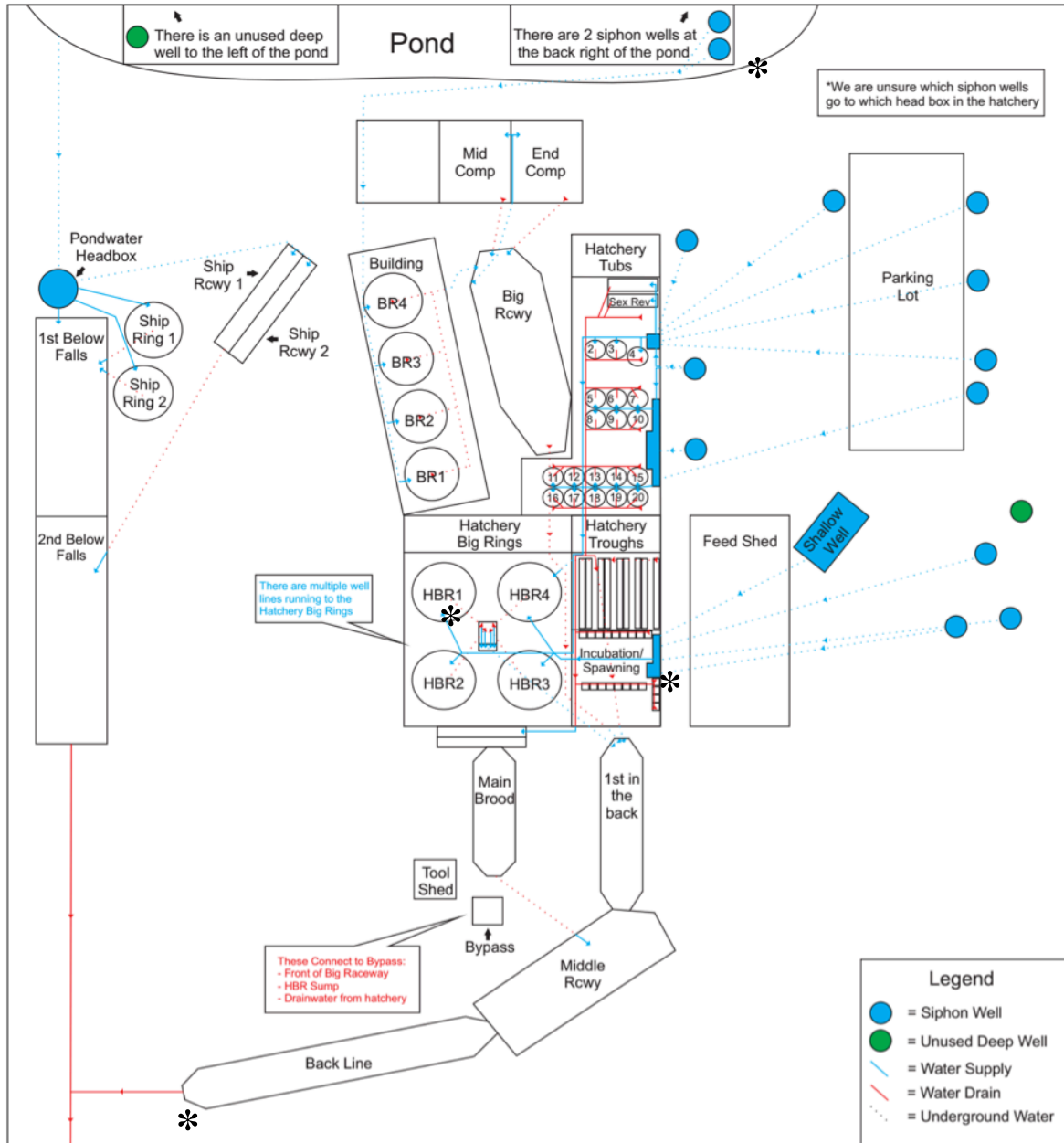

Figure A1. Schematic of local flow-through aquaculture system depicting water flow and hatchery design. Sample locations are denoted by asterisks.

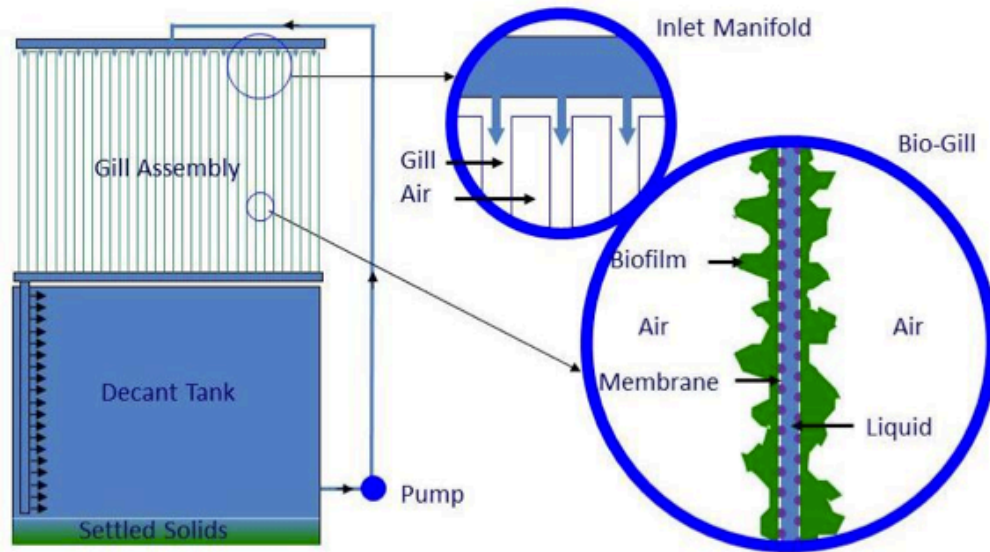

Figure A2. Schematic representation of the nano-membrane bioreactor treatment technology (NMB) provided by BioGill™. Wastewater is re-circulated through the set of gills via a pump, returning to the tank under the effects of gravity. Each gill consists of a pair of planar membranes oriented vertically with the liquid trickling down between them. Air surrounding the gills provides the oxygen to feed the growing biomass (biofilm) that grows on the membranes from the outside, while soluble nutrients are located in the inner lumen of the gills and feed the microbial population. (Image adapted from BioGill™, 2014)

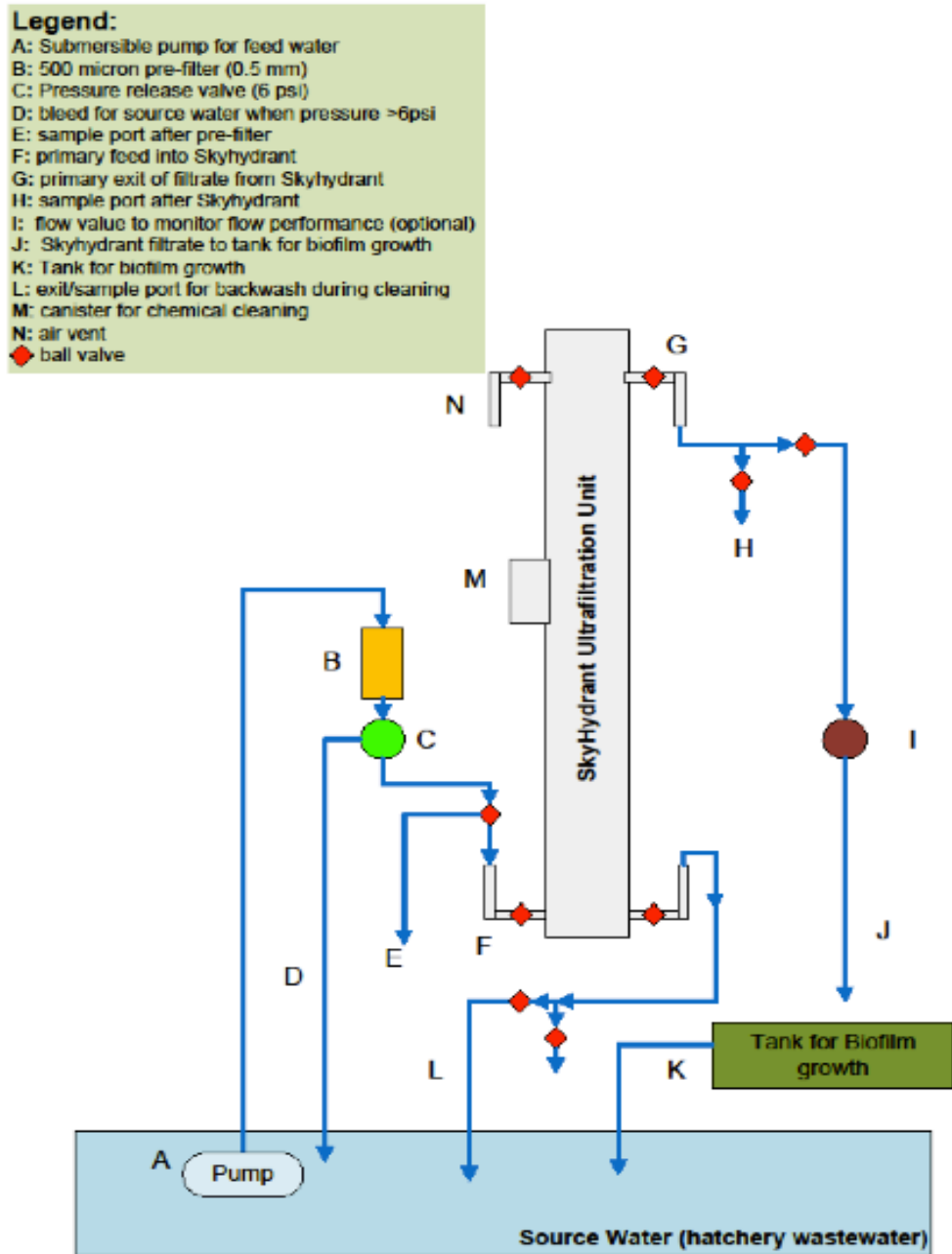

Figure A3. Schematic of the ultra-filtration technology set up within the pilot-scale recirculating system. (Image provided by Skyhydrant™)

A1 Water	A2 β-Methyl-D- Glucoside	A3 D-Galactonic Acid γ-Lactone	A4 L-Arginine	A1 Water	A2 β-Methyl-D- Glucoside	A3 D-Galactonic Acid γ-Lactone	A4 L-Arginine	A1 Water	A2 β-Methyl-D- Glucoside	A3 D-Galactonic Acid γ-Lactone	A4 L-Arginine
B1 Pyruvic Acid Methyl Ester	B2 D-Xylose	B3 D- Galacturonic Acid	B4 L-Asparagine	B1 Pyruvic Acid Methyl Ester	B2 D-Xylose	B3 D- Galacturonic Acid	B4 L-Asparagine	B1 Pyruvic Acid Methyl Ester	B2 D-Xylose	B3 D- Galacturonic Acid	B4 L-Asparagine
C1 Tween 40	C2 l-Erythritol	C3 2-Hydroxy Benzoic Acid	C4 L- Phenylalanine	C1 Tween 40	C2 l-Erythritol	C3 2-Hydroxy Benzoic Acid	C4 L- Phenylalanine	C1 Tween 40	C2 l-Erythritol	C3 2-Hydroxy Benzoic Acid	C4 L- Phenylalanine
D1 Tween 80	D2 D-Mannitol	D3 4-Hydroxy Benzoic Acid	D4 L-Serine	D1 Tween 80	D2 D-Mannitol	D3 4-Hydroxy Benzoic Acid	D4 L-Serine	D1 Tween 80	D2 D-Mannitol	D3 4-Hydroxy Benzoic Acid	D4 L-Serine
E1 α- Cyclodextrin	E2 N-Acetyl-D- Glucosamine	E3 γ- Hydroxybutyric Acid	E4 L-Threonine	E1 α- Cyclodextrin	E2 N-Acetyl-D- Glucosamine	E3 γ- Hydroxybutyric Acid	E4 L-Threonine	E1 α- Cyclodextrin	E2 N-Acetyl-D- Glucosamine	E3 γ- Hydroxybutyric Acid	E4 L-Threonine
F1 Glycogen	F2 D- Glucosaminic Acid	F3 Itaconic Acid	F4 Glycyl-L- Glutamic Acid	F1 Glycogen	F2 D- Glucosaminic Acid	F3 Itaconic Acid	F4 Glycyl-L- Glutamic Acid	F1 Glycogen	F2 D- Glucosaminic Acid	F3 Itaconic Acid	F4 Glycyl-L- Glutamic Acid
G1 D-Cellobiose	G2 Glucose-1- Phosphate	G3 α-Ketobutyric Acid	G4 Phenylethyl- amine	G1 D-Cellobiose	G2 Glucose-1- Phosphate	G3 α-Ketobutyric Acid	G4 Phenylethyl- amine	G1 D-Cellobiose	G2 Glucose-1- Phosphate	G3 α-Ketobutyric Acid	G4 Phenylethyl- amine
H1 α-D-Lactose	H2 D,L-α- Glycerol Phosphate	H3 D-Malic Acid	H4 Putrescine	H1 α-D-Lactose	H2 D,L-α- Glycerol Phosphate	H3 D-Malic Acid	H4 Putrescine	H1 α-D-Lactose	H2 D,L-α- Glycerol Phosphate	H3 D-Malic Acid	H4 Putrescine

Figure A4. Representation of the Biolog© EcoPlate™ containing 31 carbon sources in triplicate. (image adapted from www.biolog.com)

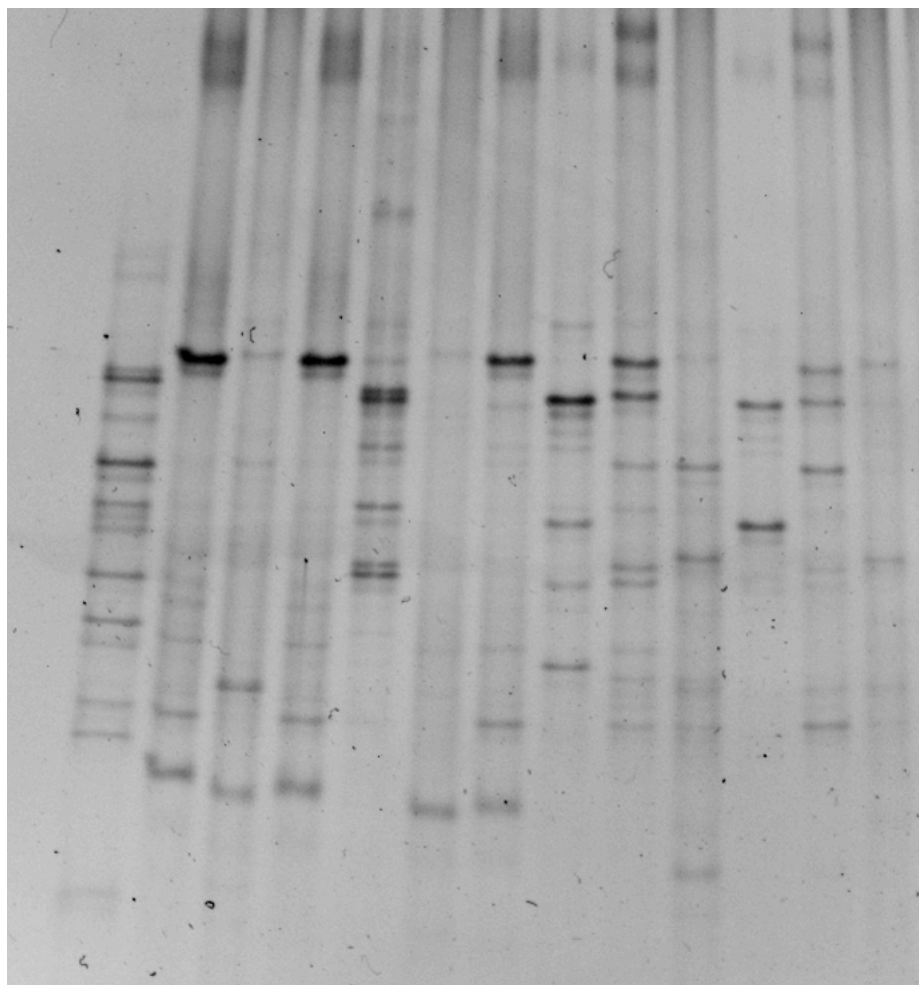

Figure A5. Sample image of an 8% DGGE gel with a urea/formamide gradient of 40-65% used to separate DNA fragments from the pilot-scale UF treated system (weeks 1, 3, 5, 7) amplified with primer pair 357f-GC-518r. Ladder is in lane 1. All other lanes are loaded with sample.

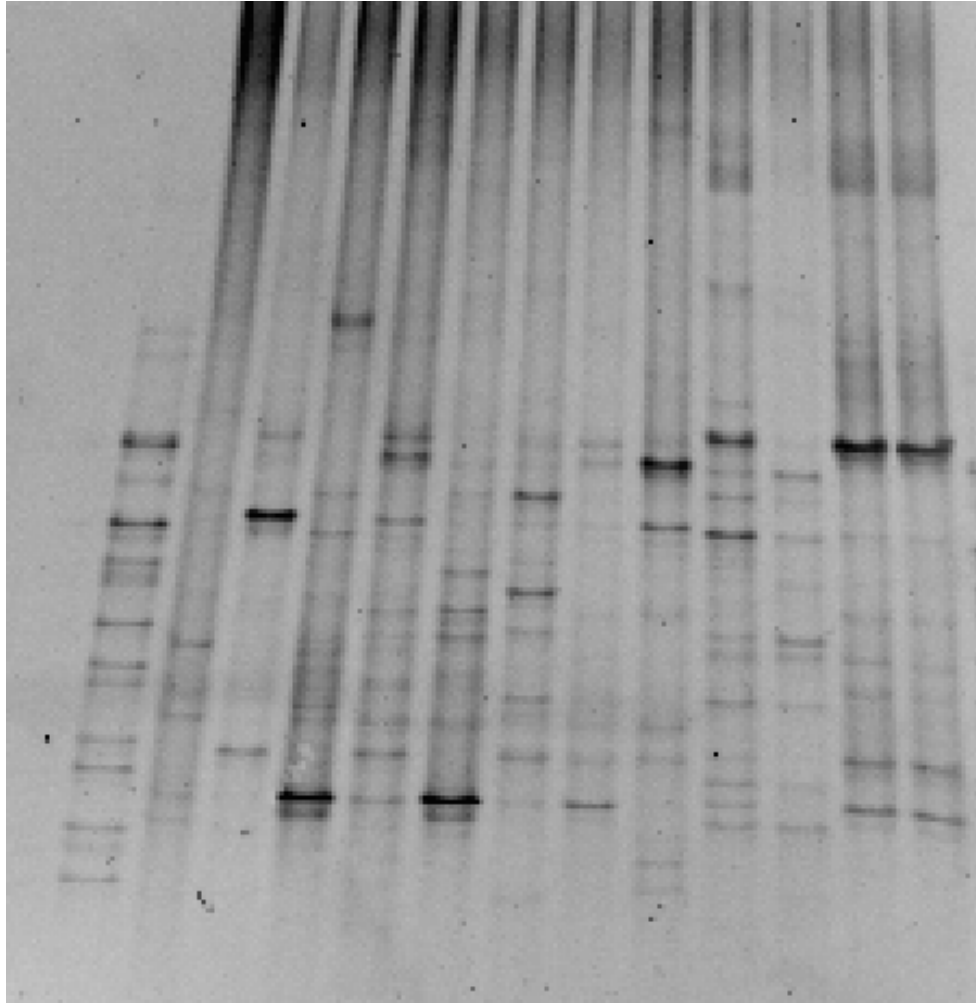
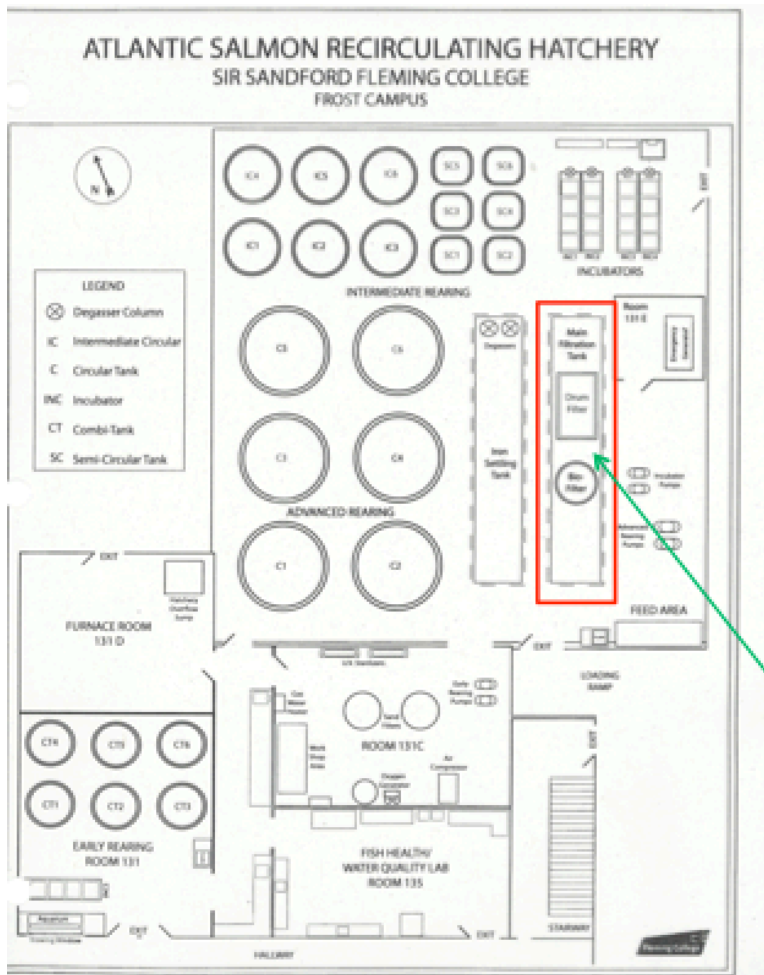

Figure A6. Sample image of an 8% DGGE gel with a urea/formamide gradient of 40-65% used to separate DNA fragments from the Northern flow-through system (FTS-A) amplified with primer pair 357f-GC-518r. Ladder is in lane 1. All other lanes are loaded with sample.



The green arrow identifies the collection site of the effluent rearing water to be used for the source water to the NMB and UF pilot-scale systems.

Figure A7. Schematic of recirculating hatchery from which influent water supplying pilot-scale systems A and B (RAS-A and RAS-B) are derived.